

USER MANUAL
MANUALE D'USO

GS 60

SPEAKER FOR
GARDENS

DIFFUSORE ACUSTICO
PER GIARDINO



**IMPORTANT NOTES**

Before connecting and using this product, please read this instruction manual carefully and keep it on hand for future reference. This manual is to be considered an integral part of this product and must accompany it when it changes ownership as a reference for correct installation and use as well as for the safety precautions.

RCF S.p.A. will not assume any responsibility for the incorrect installation and / or use of this product.

SAFETY AND OPERATING PRECAUTIONS

1. All the precautions, in particular the safety ones, must be read with special attention, as they provide important information.

2. Speaker lines (amplifier outputs) can have a sufficiently high voltage (i.e. 100-70 V) to involve a risk of electrocution: never install or connect speakers when the line is alive.

3. Make sure all connections have been made correctly and the speaker input voltage is suitable for the amplifier output.

4. Protect speaker lines from damage. Make sure they are positioned in a way that they cannot be stepped on or crushed by objects.

5. Make sure that no objects or liquids can get into this product, as this may cause a short circuit.

6. Never attempt to carry out any operations, modifications or repairs that are not expressly described in this manual.

Contact your authorized service centre or qualified personnel should any of the following occur:

- The speaker does not function (or works in an anomalous way).
- Its cable has been damaged.
- Objects or liquids have got into the unit.
- The speaker has been damaged due to heavy impacts or fire.

7. Should the speaker emit any strange odours or smoke, remove it from the line after having immediately switched the amplifier off.

8. Do not connect this product to any equipment or accessories not foreseen.

Do not try to hang this speaker by using elements that are unsuitable or not specific for this purpose.

Check the suitability of the components used for attachment (i.e. wall plugs, screws, brackets not supplied by RCF, etc.), which must guarantee the security of the system / installation over time, also considering, for example, the mechanical vibrations normally generated by transducers.

IMPORTANT NOTES

9. RCF S.P.A. strongly recommends this product is only installed by professional qualified installers (or specialised firms) who can ensure a correct installation and certify it according to the regulations in force.

The entire audio system must comply with the current standards and regulations regarding electrical systems.

10. Mechanical and electrical factors need to be considered when installing a professional audio system (in addition to those which are strictly acoustic, such as sound pressure, angles of coverage, frequency response, etc.).

11. Hearing loss

Exposure to high sound levels can cause permanent hearing loss. The acoustic pressure level that leads to hearing loss is different from person to person and depends on the exposure time.

To prevent potentially dangerous exposure to high levels of acoustic pressure, anyone who is exposed to these levels should use adequate protection devices.

When a transducer capable of producing high sound levels is being used, it is necessary to wear ear plugs or protective earphones.

See the technical specifications in the instruction manual for the maximum sound pressure of the speaker.

12. To ensure a correct sound reproduction, speaker phase is to be respected (loudspeakers are connected respecting the amplifier polarity). This is important when speakers are installed adjacent one another, for instance, in the same room. Make sure speaker lines are not shorted before turning the amplifier on.

13. To prevent inductive effects from causing hum, noise and a bad system working, speaker lines should not be laid together with other electric cables (mains), microphone or line level signal cables connected to amplifier inputs.

14. The speaker cable shall have wires with a suitable section (twisted, if possible, to reduce inductive effects due to surrounding electro-magnetic fields) and a sufficient electrical insulation. Refer to local regulations, as there may be additional requirements about cable characteristics.

15. Install this speaker far from any heat source.

16. Do not use solvents, alcohol, benzene or other volatile substances for cleaning the external parts of this product. Use a dry cloth.

RCF S.P.A. THANKS YOU FOR PURCHASING THIS PRODUCT, WHICH HAS BEEN DESIGNED TO GUARANTEE RELIABILITY AND HIGH PERFORMANCE.

DESCRIPTION AND PLACEMENT



GS 60 is an outdoor speaker suitable for gardens that includes a 5" coaxial loudspeaker and an internal transformer for 100 V / 70 V constant voltage lines.

Take off the GS 60 speaker from the packaging (which should be kept for a possible reuse). Should the speaker be damaged, do not use it, but contact your authorized dealer.

INSERTS FOR
FIXING GS 60
TO A BRACKET
(not included)
TO BE BURIED
IN THE GROUND

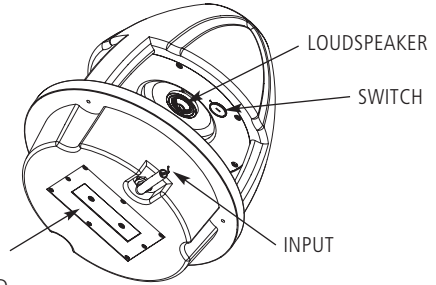

GS 60 can be placed on several surfaces, such as wood, concrete or into the ground.

When choosing a location, keep in mind the following guidelines:

- Choose a flat surface in order to prevent any movement or vibration during its use.
- Place speakers where their cables could not be trod or pulled.
- Do not place speakers on grounds that could get ponds when it is raining.
- Do not bury GS 60 speakers deeper than 3" (76 mm).

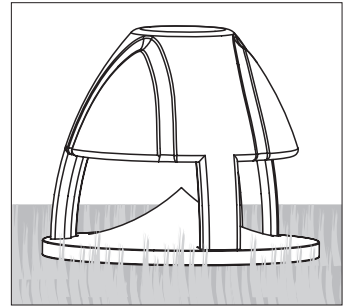

CONNECTION AND POWER SELECTION



WARNING: ensure speaker connections are made properly only by qualified and experienced personnel having the necessary technical know-how or sufficient specific instructions, in order to prevent any electrical danger.

To prevent any risk of electric shock, do not connect speakers when the amplifier is switched on. Before turning the system on, check all connections and make sure there are no accidental short circuits. The entire sound system shall be designed and installed in compliance with the current local laws and regulations regarding electrical systems.

The speaker has two wires for connection: red (+) and black (-).

Connect the amplifier positive output (usually marked with either '+' or '100 V' / '70 V' or 'a') to the speaker red wire.

Connect the amplifier negative output (usually marked with either '-' or '0' or 'COM' or 'b') to the speaker black wire.

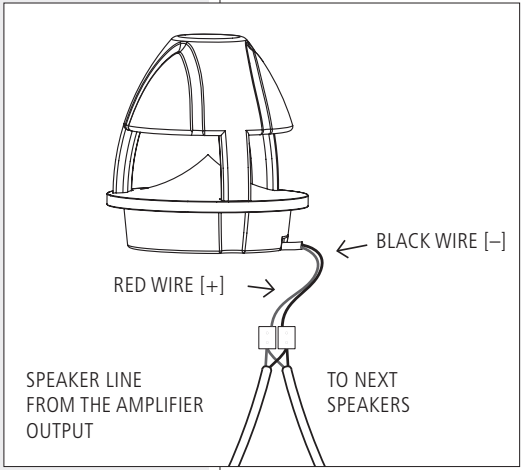

Connections can be protected by soldering the wires together with heat shrink tubing to seal or using waterproof connectors.

Depending on the installation type, the direct burial of the speaker cable may be adequate, but the use of suitable PVC pipelines is strongly recommended to protect cables against damage (for instance, due to excavations in the installation area).

Always use moisture-resistant cables.

If loudspeaker cables may be exposed to salt water or containing chemicals (e.g. chlorine, fertilizers), it is advisable to use silicone caulking materials as additional protection for loudspeaker connections.

Set the switch to the proper power value [W] (indicated by the arrow).

8 Ω = low impedance direct connection (without internal transformer)

∅ = not allowed (100 V line)

IMPORTANT NOTES:

- WHEN SET TO 8 Ω (LOW IMPEDANCE), NEVER CONNECT THE SPEAKER TO A 100 / 70 V LINE.
- WHEN SET TO 32 W @ 70 V, NEVER CONNECT THE SPEAKER TO A 100 V LINE.

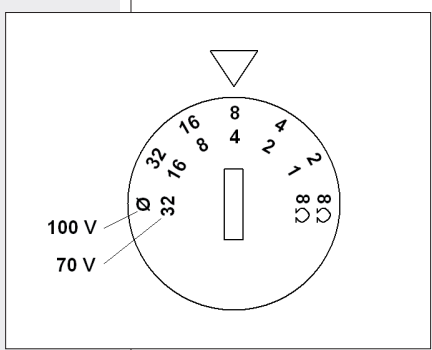

NOTES ABOUT CONSTANT VOLTAGE SYSTEMS



- The loudspeaker input voltage (V_d) shall correspond to the amplifier output voltage (V_a).
- The sum of nominal power values ($P_d \times n$) of all loudspeakers connected to the line shall not exceed the amplifier power (P_a).

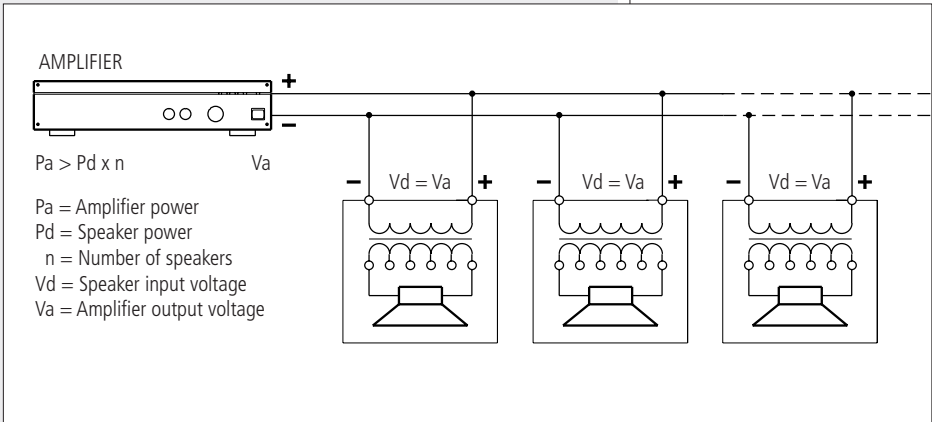

NOTES ABOUT (8 Ω) LOW IMPEDANCE CONNECTIONS



- The total loudspeaker impedance must not be lower than the amplifier output impedance. A loudspeaker total impedance equal to the amplifier output one permits to get the maximum deliverable power (but an higher loudspeaker impedance entails less power).
- The total loudspeaker power shall be adequate for the maximum deliverable power of the amplifier.
- The loudspeaker line shall be short (for long distances, it may be necessary to use cables with large cross-section wires).
- Do NOT connect the low impedance input directly to 70 / 100 V constant voltage lines.

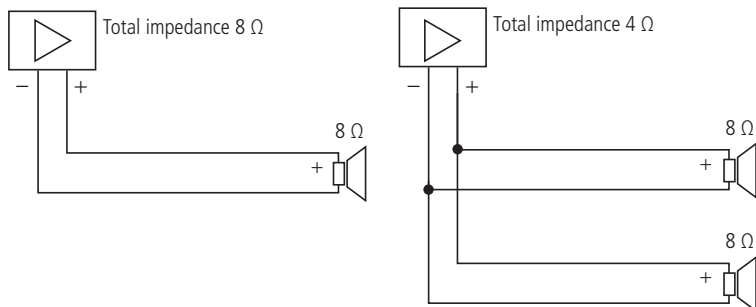

OTHER CABLE NOTES



- Always use cables having wires with an adequate cross-section, considering the cable length and the total loudspeaker power.
- Loudspeaker lines must be kept separated from mains cable, microphone cables or others, in order to avoid inductive phenomena may cause hum or noises.
- Use loudspeaker cables having twisted wires to reduce hum caused by inductive effects due to coupling with electromagnetic fields.
- Make sure all loudspeakers are connected in phase to ensure a correct sound reproduction.



INPUT:	100 / 70 V (constant voltage) 8 Ω (low impedance)
POWER (100 V, SELECTABLE):	32 – 16 – 8 – 4 – 2 W
POWER (70 V, SELECTABLE):	32 – 16 – 8 – 4 – 2 – 1 W
POWER (RMS, 8 Ω):	60 W
POWER (PEAK, 8 Ω):	120 W
FREQUENCY RESPONSE (–10 dB):	60 Hz ÷ 20 kHz
SENSITIVITY (1 W, 1 m):	90 dB
MAX. SOUND PRESSURE LEVEL (1 m):	111 dB
COAXIAL TRANSDUCER:	5.25" (133 mm) woofer (1" voice coil), 1.20" (30 mm) dome tweeter
ENCLOSURE MATERIAL:	linear low-density polyethylene
COLOUR:	green
IP PROTECTION GRADE:	IP 56
DIMENSIONS:	ø 365 mm, height: 409 mm



Salvo eventuali errori ed omissioni.

RCF S.p.A. si riserva il diritto di apportare modifiche senza preavviso.

Except possible errors and omissions.

RCF S.p.A. reserves the right to make modifications without prior notice.

www.rcf.it

RCF S.p.A. Italy

Via Raffaello Sanzio, 13

42124 Reggio Emilia - Italy

Tel +39 0522 274 411

Fax +39 0522 232 428

e-mail: info@rcf.it