



# Operation Manual

Version 2.0



**E Series**

**E-6, E-8, E-10, E-12, E-15  
ESW-110, ESW-115, ESW-118**

Keep these important operating instructions.  
*Check [www.tecnare.com](http://www.tecnare.com) for updates.*



### **General Information**

E Series Operation Manual

Ver.: 2.0\_UK 02/2017

©EXEL ACOUSTICS SL; all right reserved

The information contained in this manual has been carefully checked for accuracy, at the time of going to press, however no guarantee is given with respect to the correctness.

Exel Acoustics SL accepts no responsibility for any errors or inaccuracies that may appear in this manual or the products and software described in it. Technical specifications, dimensions, weights and properties do not represent guaranteed qualities. As manufacturers we reserve the right to make alterations and modifications within the framework of legal provisions, as well as changes aimed at improving quality.

### **EXEL ACOUSTICS SL**

CL Encinar, 282 – Pol. Ind. Monte Boyal

45950 Casarrubios del Monte (Toledo) Spain

Phone: (+34) 918 170 110 Fax:

e-mail: [support@tecnare.com](mailto:support@tecnare.com) [www.tecnare.com](http://www.tecnare.com)

## IMPORTANT SAFE INSTRUCTIONS

Before using our product, be sure to carefully read the manual and safe instructions. Keep this document with the device all time.



several enclosure on top of one another, use straps to secure them against movement.

- 1 Read these instructions.
- 2 Keep these instructions.
- 3 Heed all warnings.
- 4 Follow all SAFETY INSTRUCTIONS as well DANGER and OBLIGATION warnings.
- 5 Only use attachments / accessories specified by the manufacturer.
- 6 Use only with the cart, tripod, bracket or table specified by the manufacturer, or sold with the apparatus. When a cart is used, use caution when moving the cart / apparatus combination to avoid injury from tip-over.
- 7 If the equipment is used in a manner not specified by the Exel Acoustic, the protection by the equipment may be impaired.
- 8 Read all the Product Information document before exploiting the system.
- 9 Read the Rigging Manual before installing the system. Use the rigging accessories described in the rigging manual and follow the associated procedures.

**CAUTION:** Rigging should only be done by experience professionals.

- 10 This speaker enclosure is capable of creating a strong magnetic field. Please use caution around the enclosure with data storage devices such as phones, computers or hard drivers.
- 11 Handles are for moving the system only.
- 12 **Beware of sound levels.** Never stand in the immediate vicinity of loudspeaker driven at high level. Professional loudspeaker systems are capable of causing a sound pressure level (SPL) detrimental to human health. Hearing damage can also occur with prolonged exposure to sound: 8h at 90 dB(A), 30 min at 110 dB(A), less than 4 min at 130 dB(A) *Source: European Directive relating to the assessment and management of noise 2002/49/CE*
- 13 When setting up the loudspeaker or loudspeaker stand, make sure they are standing on a firm surface. If you place

## SYMBOLS USED

		
Important operating instructions	Additional information	OBLIGATION. This instructions must be strictly followed
Pour indequer important Instructions	Information complémentaire	Obligation. Cela doit être strictement instructions Suivi
Wichtige Betriebsanweisung oder Gebrauchsanleitung	Informationen. Zusätzliche Informationen	Pflicht. Diese Anweisungen müssen strikt befolgt
Importantes instrucciones operativas	Información complementaria	Obligación. Estas instrucciones deben ser estrictamente seguidas

## **DECLARACIÓN DE CONFORMIDAD**

### **DECLARATION OF CONFORMITY**

#### **EXEL ACOUSTICS SL**

CL Encinar, 282. Polígono Industrial Monte Boyal. 45950 – Casarrubios del Monte (Toledo), España (Spain).

Declara que los productos **E Series** y sus respectivas opciones, cumple con las Directivas:

*Declare under our sole responsibility that devices in the **E Series** range of products, comply with relating Directives:*

- (1) Directiva de Baja Tensión - 2006/95/CE
- (2) Directiva de Compatibilidad Electromagnética - 2004/108/CE
- (3) Directiva RoHS - 2011/65/UE
- (4) Directiva RAEE - 2012/19/UE

- (1) *Low Voltage Directive 2006/95/CE*
- (2) *EMC 2004/108/CE*
- (3) *RoHS Directive 2011/65/UE*
- (4) *WEEE Directive 2012/19/UE*

# Table of Contents

IMPORTANT SAFE INSTRUCTIONS.....	3
DECLARACIÓN DE CONFORMIDAD .....	5
1 Introduction .....	7
1.1 Welcome to Tecnare .....	7
1.2 Overview.....	8
1.3 The E Series Loudspeaker .....	9
1.4 Connections .....	12
1.5 Processing and Amplification.....	13
2 Loudspeakers Configurations .....	14
2.1 Full Range Stereo/Parallel configuration .....	14
2.2 Full Range with low-frequency element.....	14
2.3 Recommended Amplifier Power.....	15
2.4 Recommended Speaker Cables .....	15
3 Flying and Suspension.....	16
3.1 Important Safety Warning.....	16
3.2 Placement.....	16
3.3 Tripod Use .....	17
3.4 Flying.....	17
4 Technical specifications.....	19

# 1 Introduction

## 1.1 Welcome to Tecnare

Thank you for choosing the high-quality Tecnare® **E-Series System “Made in Spain”** from **EXEL ACOUSTICS SL**.

Please spare a little time to study the contents of this manual, so that you obtain the best possible performance from this unit.

All Tecnare® products are carefully engineered for world-class performance and reliability.

If you would like further information about this or any other Tecnare® product, please contact us. We look forward to helping you in the near future.

**As part of a continuous evolution of techniques and standards, Exel Acoustics SL as manufacturer of Tecnare® products reserve the right to change the specifications of its products and the content of its documents without prior notice.**

Updates and supplementary information are available on the Tecnare® website:

<http://www.tecnare.com>

Tecnare Technical Support is available at:

- (T): +34 918 170 110 - +34 918 171 001
- (e-mail): [support@tecnare.com](mailto:support@tecnare.com)

Thank you again for placing your confidence in Tecnare® products.



## 1.2 Overview

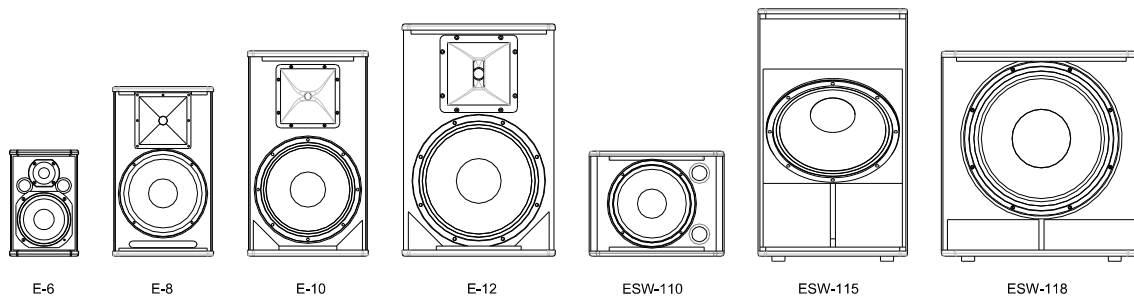

**E Series** is a line of low-cost speakers that deliver the best relationship price-quality, power handling, and rugged build in their class. Custom built, industry leading Tecnae transducers and enclosures give E SERIES the power and ruggedness to stand up to a variety of demanding applications and provide reliable, highest quality sound wherever it is needed.

The E Series system range and components are formed from:

- **E-6, passive ultra-compact enclosure, 135°H x 125°V, 70Hz to 18kHz;**
- **E-8, passive compact enclosure, 130° axi-symmetric, 80Hz to 18kHz;**
- **E-10 passive/active compact enclosure, 120°H x 100°V, 50Hz to 20kHz;**
- **E-12 passive/active enclosure, 120°H x 80°V, 50Hz to 20kHz;**
- **E-15 passive/active enclosure, 120°H x 80V, 45Hz to 16kHz;**
- **ESW-110 passive compact subwoofer enclosure, 45Hz to 500Hz;**
- **ESW-115 passive/active high-power horn-loaded subwoofer, 43Hz to 130Hz;**
- **ESW-118 passive/active bass-reflex subwoofer, 38Hz to 150Hz;**

The seven new systems are designed for use in a variety of applications. All models are equipped with multiple M6, M8 and M10 attachment points and additional installation-friendly features and utilize a rugged grille design and system appearance suitable for nearly all indoor environments.

The E Series is suited to various sound reinforcement applications as a main or complementary system.

The line will include optionally U-brackets, ceiling brackets and a wall mount bracket accessory for all full-range models.

## 1.3 The E Series Loudspeaker

### FEATURES

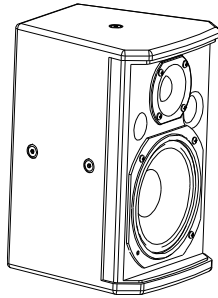

#### **E-6**

The Tecna E6 loudspeakers are comprised of:

- One 6.5-inch driver
- one 1-inch HF compression driver.
- Built-in rigging points (eyebolt)

The E-6 is a ultra-compact 2-way passive loudspeaker that used a 6.5" low-mid frequency transducer in a bass-reflex cabinet and an 1" compression driver. The internal passive crossover network uses a custom filters.

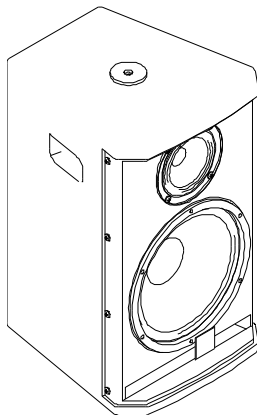

#### **E-8**

The Tecna E8 loudspeakers are comprised of:

- One 8-inch driver
- one cone paper tweeter.
- Built-in rigging points (eyebolt)

The E-8 is a compact 2-way passive loudspeaker that used a 8" low-mid frequency transducer in a bass-reflex cabinet and an one soft cone paper tweeter it gives a smooth tonal response. The internal passive crossover network uses a custom filters.

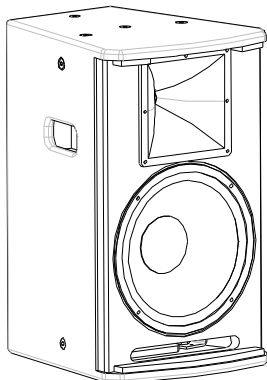

#### **E-10**

The Tecna E10 loudspeakers are comprised of:

- One 12-inch driver
- one 1-inch HF compression driver
- Built-in rigging points (eyebolt)
- A Pole mount socket

The E-12 is a compact 2-way passive loudspeaker that used a 10" low-mid frequency transducer in a bass-reflex cabinet and a 1" compression driver.. The internal passive crossover network uses a custom filters.

### **E-12**

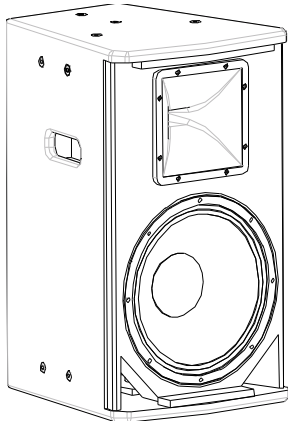

The Tecnare E12 loudspeaker are comprised of:

- One 12-inch driver
- one 1-inch HF compression driver on a CD Horn
- Built-in rigging points (eyebolt)
- A Pole mount socket

The E-12 is a compact 2-way passive loudspeaker that used a 6.5" low-mid frequency transducer in a bass-reflex cabinet and a 1" compression driver attached on a CD Horn. The internal passive crossover network uses a custom filters.

### **E-15**

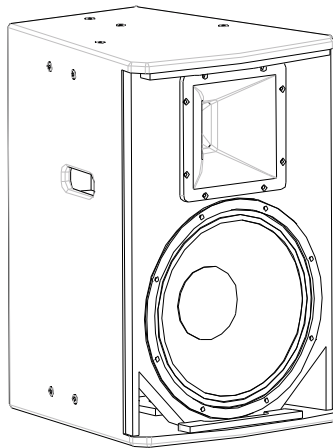

The Tecnare E15 loudspeaker are comprised of:

- One 15-inch driver
- one 1.4-inch HF compression driver on a CD Horn
- Built-in rigging points (eyebolt)
- A Pole mount socket

The E-15 is a compact 2-way passive loudspeaker that used a 15" low-mid frequency transducer in a bass-reflex cabinet and a 1" compression driver attached on a CD Horn. The internal passive crossover network uses a custom filters.

### **ESW-110**

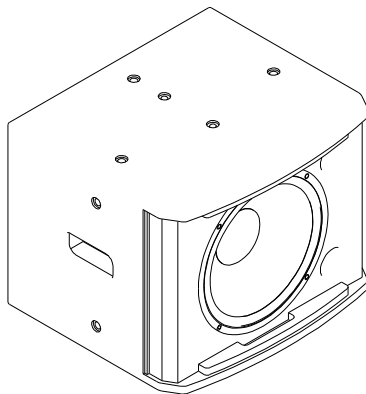

The Tecnare ESW-110 bass-reflex subwoofer system are comprised of:

- One 10-inch driver
- Ultra-compact enclosure
- Built-in rigging points (eyebolt)
- Sonic impact precision

The ESW-110 is a ultra-compact subwoofer system that incorporates a 18" trasducer in a bass-reflex cabinet. Two recessed handles makes moving easy.

### **ESW-115**

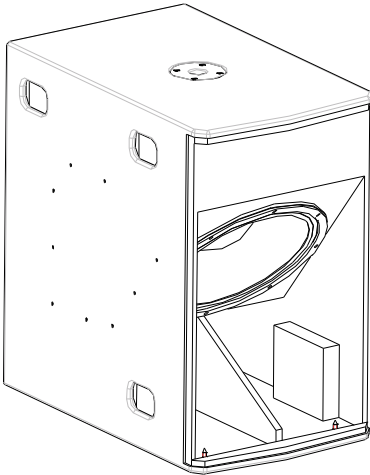

The Tecnare ESW-115 loudspeakers are comprised of:

- One 15-inch long excursion driver
- 3/side recessed handles
- Top located pole mount socket

The ESW-115 is band pass rear horn-loaded subwoofer that used a 15" long excursion low frequency transducer. The response given is very deep, starting at 38Hz. The loudspeaker is protected by a perforated steel grille. The top located pole-mount socket permits mounting full-range systems above ESW-115.

### **ESW-118**

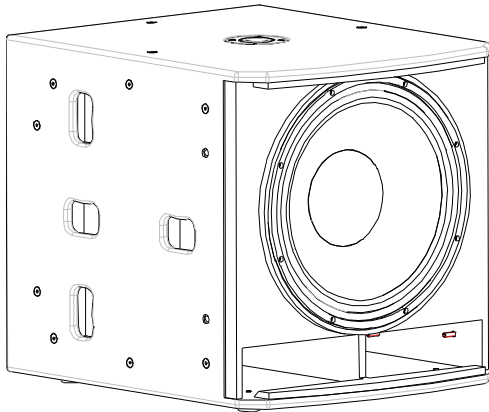

The Tecnare ESW-118 loudspeakers are comprised of:

- One 18-inch long excursion driver
- 4/side recessed handles
- Top located pole mount socket

The ESW-118 is a vented-box that used a 18" low frequency transducer. The rectangular cabinet is fitted with M10 threaded suspension points. The top located pole-mount socket permits mounting full-range systems above ESW-118.

## 1.4 Connections

**E Series** loudspeakers utilize Neutrik® SpeakON® connectors. There are two NLT4 connectors on the rear of each E Series enclosure. These connectors mate with Neutrik® NL-4 or NL-4 compatible in-line cable connectors. The pins 1+/1- of both connectors are wired in parallel to link multiple loudspeakers on a single amplifier output. Remember that parallel connection reduces the total impedance ( $\Omega$ ) seen by the amplifier.



The total impedance of loudspeaker connected in parallel must not drop below the minimum operating impedance of the amplifier.

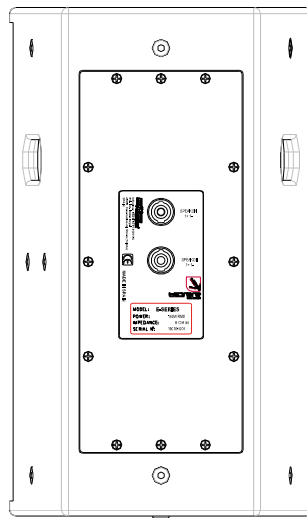

The following subsections describe the electrical connections of E-6, E-8, E10, E-12, and E-15.

IN speakON® point	1+	1-	2+	2-
Connection	IN +	IN -	NC	NC

The E Series uses the pin assignment 1+/1+.

Using one as the input, the second connector allows for direct connection to a second cabinet.

The following subsections describe the electrical connections of ESW-110, ESW-115, and ESW-118.

IN speakON® point	1+	1-	2+	2-
Connection	LF +	LF -	NC	NC

The E Series' subwoofers use the pin assignment 1+/1+.

Using one as the input, the second connector allows for direct connection to a second cabinet.

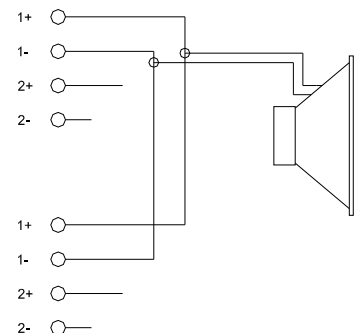
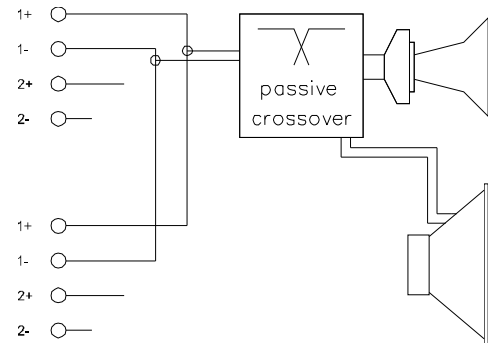

## 1.5 Processing and Amplification

Only operate Tecnare loudspeaker with a correctly configured Tecnare preset. Tecnare offer a complete solution that guarantees the highest level of performance. A complete range of controllers, amplified and amplified controller with DSP are available to get this objective. Otherwise, there is a risk of damaging the loudspeaker components.

### 1.5.1 Processing

There are two options using our digital controllers. Our **DP2696** or **DP4896**. The options vary depending on the final application. *Refer to DP2696 or DP4896 user manual.*

Preset for DP Series processors have been developed for the E Series. You may obtain the settings from the DP Series at <http://www.tecnare.com> website.

### 1.5.2 Amplification

To power *E Series*, Tecnare recommends amplifiers with the power ratings enough to feed the loudspeakers. For high power or live applications, it is recommended to oversize the amplifiers relative to the nominal AES output of the subwoofers. In certain specific cases it is possible to slightly under-power the subs or loudspeakers as long as the amplifier will not be driven to its limits.

In any case, the Tecnare processors should be deployed in front of the amp to ensure that the amplifiers to not go into clip.

The **DP4896** processors also include:

- Virtual Xover Limiter for passive systems
- Thermal protection from power surges or overload
- Xmax Excursion displacement protection

The **T20-44** amplifier is the ideal companion for maximum performance of the E Series loudspeakers. This amplifier controller with DSP offer a complete both preset and protection solution for any application.

## 2 Loudspeakers Configurations

### 2.1 Full Range Stereo/Parallel configuration

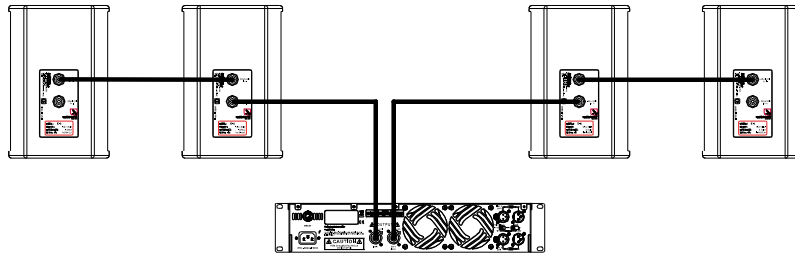

Each enclosure type is driven by the **PA Series** amplifier according to the cabinet power requirements. Correct factory preset is needed.

Connect the amplifier's output to the Speakon's input of the first cabinet, always respecting the polarity positive +1, negative -1. Then, linking from the first cabinet to the second one. This configuration allows you to connect up to four cabinets to the same amplifier with PA/2 channels Series and up to eight enclosures to the same amplifier with PA/4 channels Series.

### 2.2 Full Range with low-frequency element

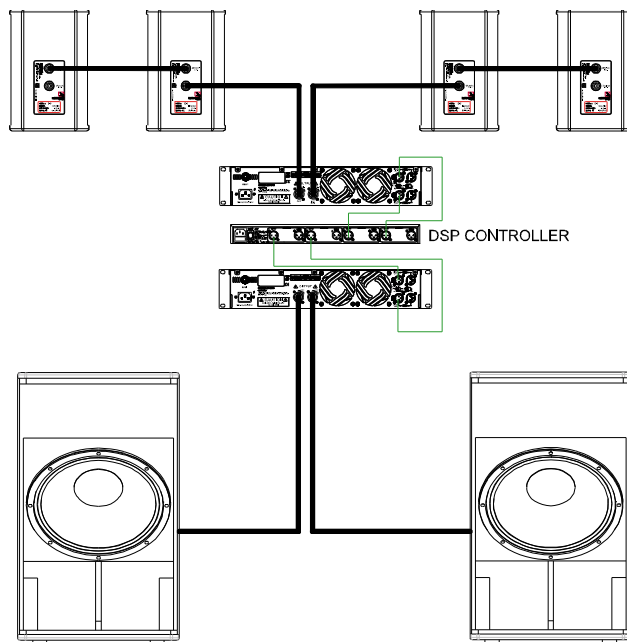

In this configuration, the frequency range of the full range system is extended in the low end.

Each enclosure type is driven by the PA Series amplifier according to the cabinet power requirements. Correct factory preset is needed.

Connect each one of the subwoofers to the two outputs of the amplifier and consequently, connecting the Full Range cabinets to a second amplifier.

## 2.3 Recommended Amplifier Power

Model	Full-Range/ Parallel	Model recommended
E-6	80 to 320 W @ 8Ω	PA900/PA4.450
E-8	100 to 400 W @ 8Ω	PA900/PA4.450
E-10	200 to 800 W @ 8Ω	PA900/PA4.450
E-12	250 to 1.000 W @ 8Ω	PA900/PA2100/PA4.450
E-15	350 to 1.400 W @ 8Ω	PA900/PA2100/PA3000/PA4.450 PA4.1500
ESW-110	120 to 480 W @ 8Ω	PA900/PA4.450
ESW-115	500 to 2.000 W @ 8Ω	PA2100/PA3000/PA5000 PA4.1500
ESW-118	600 to 2.400 W @ 8Ω	PA2100/PA3000/PA5000 PA4.1500

## 2.4 Recommended Speaker Cables

Choosing the right wire gauge for your installation is unmost importance to ensure you will get the maximum potential of your system.

The two primary things resistance affects in the amplifier-to-loudspeaker connection are: **insertion loss** and **damping factor**, both of which are dependent upon cable resistance.

### INSERTION LOSS

Insertion loss is the measure of the loss of load power at the speaker due to excessive resistive losses of the cable or any additional component attached between the amplifier and the loudspeaker. We typically express this loss in decibels (dB) using the following formula:

$$IL = 20 \bullet \log \left( \frac{R_{load}}{R_{load} + R_{cable}} \right)$$

### DAMPING FACTOR

Damping factor is a ratio of rated loudspeaker impedance (Z<sub>L</sub>) to the source impedance (Z<sub>s</sub>). In this case our source impedance is (R<sub>cable</sub> + R<sub>amplifier</sub>).

$$\text{Damping Factor} = Z_L/Z_s$$

cable cross-section			Recommended maximum length					
			8 Ω		4 Ω		2 Ω	
mm <sup>2</sup>	SWG	AWG	m	ft	m	ft	m	ft
2,5	15	13	30	100	15	50	10	33
4	13	11	50	160	25	80	17	53
6	11	9	74	240	37	120	25	80
10	9	7	120	390	60	195	40	130



## 3 Flying and Suspension

Tecnare E series offers 4 kind optional accessories for suspendable: BR U-Bracket, HG1 Wall and Truss Bracket, HG2 Ceiling Bracket and TSC-350 Wall Mount.

Before attempting to suspend your speakers, read and understand the following safety information.

### 3.1 Important Safety Warning



The information in this section has been assembled from recognized engineering data and is intended for informational purposes only. None of the information in this section should be used without first obtaining competent advice with respect to applicability to a given circumstance. None of the information presented herein is intended as a representation or warranty on the part of Tecnare. Anyone making use of this information assumes all liability arising from such use.

Correct use of all rigging hardware is required for secure system suspension. Careful calculations should always be performed to ensure that all components are used within their working load limits before the array is suspended. Never exceed the maximum recommended load ratings.

Before suspending any speaker system always inspect all components (enclosure, rigging frames, pins, eyebolts, track fittings, etc.) for cracks, deformations, corrosion, missing, loose or damaged parts that could reduce strength and safety of the array.

Do not suspend the speaker until the proper corrective action has been taken.

Use only load-rated hardware when suspending E Series Loudspeaker.

### 3.2 Placement

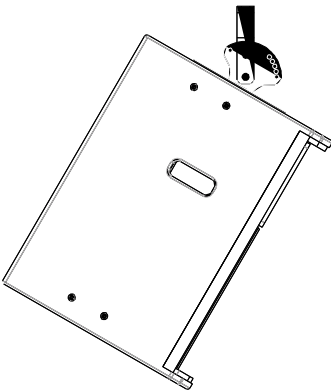

The Full Range cabinets should be located in a high position (between two or three meters), slightly inclined to the audience. If the loudspeakers are located too low, the listeners at the end of the room will not hear a good sound quality.

### 3.3 Tripod Use

The E-10, E-12 and E-15 models are equipped with a pole mount socket for use with a standard 35mm tripod.

Do not use the tripod on non-flat floors and be careful not to raise the cabinet too high on the tripod, as it may become unstable.

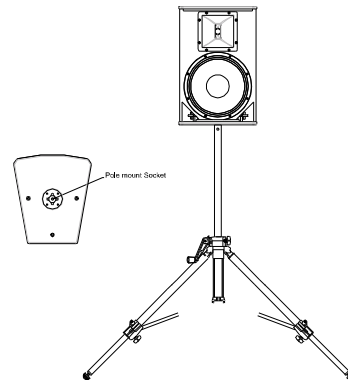

### 3.4 Flying

Only experienced installers with adequate knowledge the equipment and local safety regulations should fly speaker boxes. It is the user's responsibility to ensure that the systems to be flown (including flying accessories) comply with state and local regulations.



**CAUTION:**  
DO NOT SUSPEND THE CABINETS FROM HANDLES

#### ELEMENT FOR FLYING AND WALL-MOUNTING

##### 3.4.1 U-Bracket

E-6, E-8, E10, E12, E-15 could be flying with BR brackets.

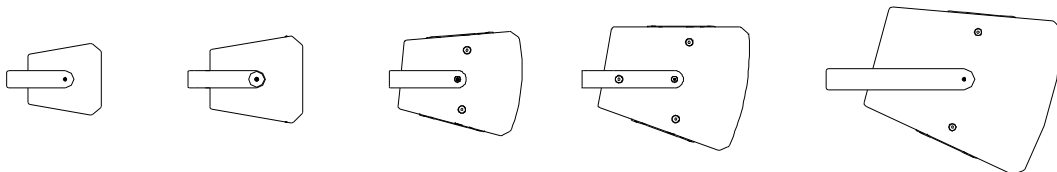

The BR is an optional accessory for wall mounting mainly for horizontal placement.

Please, refer to BR operation manual to get more information.

##### 3.4.2 HG1 Wall and Trus Bracket

It is a rigging bar for flying all the E Series Loudspeaker. The rigging system consists of four screws around the bar.

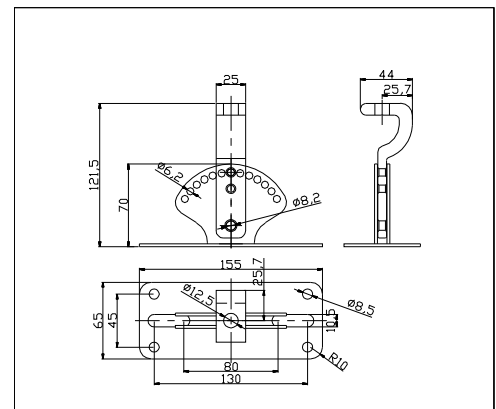

### **3.4.3 Flying with Eyebolts**

E Series loudspeakers feature several internal steel angles, with 2 mounting threads each. This angles provides different flying points. Eyebolt flying points are factory sealed with M6, M8 and M10 screws, which are replacement with eyebolt on the flying points as required. It is specially recommended for fixed installations where the boxes are permanently fixed.

## 4 Technical specifications

Model	E6	E8	E10	E12
<b>Frequency Range</b>	70 Hz to 18 kHz	80 Hz to 18 kHz	50 Hz to 20 kHz	50 Hz to 20 kHz
<b>Components</b>	LF:6,5" / HF:1"	LF: 8" / HF: cone TW	LF:10" / HF:1"	LF:12" / HF: 1"
<b>Nominal Dispersions</b>	135° x 125°	130° x 130°	120° x 100°	120° x 80°
<b>Impedance</b>	8 ohm	8 ohm	8 ohm	8 ohm
<b>Axial Sensitivity (1w/1m)</b>	88 dB SPL	90 dB SPL	91 dB SPL	93 dB SPL
<b>Calculated SPL</b>	107dB / 113dB	110dB / 116dB	114dB / 120 dB	116dB / 122dB
<b>Power Handling AES</b>	80 w	120 w	240 w	320 w
<b>Peak Power Handling</b>	160 w	240 w	480 w	640 w
<b>Dimensions (H x W x D)</b>	313 x 205 x 212 (mm) 12.32" x 8.07" x 8.34"	381 x 249 x 269 (mm) 15" x 9.8" x 10.59"	550 x 298 x 342 (mm) 21.65" x 11.73"x13.46"	606 x 357 x 404 (mm) 23.85" x 14.05 x 15.9"
<b>Net Weight</b>	5,5kg. (12.12lbs.)	7,1kg. (16.65lbs.)	13,6kg. (29.98lbs.)	21kg. (46.29lbs.)
<b>Construction</b>	Birch Plywood	Birch Plywood	Birch Plywood	Birch Plywood
<b>Connectors</b>	2 x NL4 Speakon®	2 x NL4 Speakon®	2 x NL4 Speakon®	2 x NL4 Speakon®
<b>Color</b>	Black	Black	Black	Black
<b>Accessories</b>	BR6, HG1; HG2	BR8; HG1;	BR10, HG1; HG2; TSC-350	BR12, HG1; HG2

Model	E15	ESW110	ESW115	ESW118
<b>Frequency Range</b>	45 Hz to 16 kHz	45 Hz to 500 Hz	43 Hz to 130 Hz	38 Hz to 150 Hz
<b>Components</b>	LF:15" / HF:1.4"	LF: 10"	LF:15"	LF:18"
<b>Nominal Dispersions</b>	120° x 80°	360°	120° x 120°	360°
<b>Impedance</b>	8 ohm	8 ohm	8 ohm	8 ohm
<b>Axial Sensitivity (1w/1m)</b>	95 dB SPL	94 dB SPL	95 dB SPL	96 dB SPL
<b>Calculated SPL</b>	120dB / 126dB	115dB / 121dB	121dB / 127 dB	123dB / 129dB
<b>Power Handling AES</b>	400 w	250 w	500 w	600 w
<b>Peak Power Handling</b>	800 w	500 w	1.000 w	1.200 w
<b>Dimensions (H x W x D)</b>	680 x 452 x 512 (mm) 26.77" x 17.79" x 20.15"	310 x 398 x 350 (mm) 12.2" x 15.7" x 13.78"	724 x 402 x 705 (mm) 28.5" x 15.82"x27.76"	606 x 357 x 404 (mm) 23.85" x 14.05 x 15.9"
<b>Net Weight</b>	32kg. (70.54lbs.)	9,6kg. (21.16lbs.)	37kg. (81.57lbs.)	41,6kg. (91.71lbs.)
<b>Construction</b>	Birch Plywood	Birch Plywood	Birch Plywood	Birch Plywood
<b>Connectors</b>	2 x NL4 Speakon®	2 x NL4 Speakon®	2 x NL4 Speakon®	2 x NL4 Speakon®
<b>Color</b>	Black	Black	Black	Black
<b>Accessories</b>	BR6, HG1; HG2; TSC-350	Eye bolt	Eye bolt	Eye bolt

Application information is presented for guidance only. Exel Acoustics SL reserves the right to make any necessary changes to the products and the published specifications. As part of the ongoing development program Exel Acoustics SL tries to maintain the highest degree of product compatibility.



*Reinventing The Rules*



©2017

*Tecnare Sound Systems*. All rights reserved.  
**E Series** Operation manual

The contents of this manual are furnished for informational purposes only, are subject to change without notice, and should not be construed as a commitment by Exel Acoustics SL. Exel Acoustics assumes no responsibility or liability for any errors or inaccuracies that may appear in this manual. Except as permitted by applicable copyright law, no part of this publication may be reproduced, stored in a retrieval system, or transmitted, in any form or by any means, electronic, mechanical, recording or otherwise, without prior written permission from Exel Acoustics. Tecnare and PCC-Net are trademarks of Exel Acoustics SL. Podware, BvNet, Smaart and all third-party trademarks mentioned herein are the property of their respective trademark holders.

Printed in Spain.

**EXEL ACOUSTICS SL**

CL Encinar, 282 - Pol. Ind. Monte Boyal  
45950 Casarrubios del Monte (To)  
Spain  
[support@tecnare.com](mailto:support@tecnare.com)

[www.tecnare.com](http://www.tecnare.com) - [www.facebook.com/tecnare](http://www.facebook.com/tecnare)  
(T): +34 918 170 110 - +34 918 171 001  
(F): +34 918 183 053

