

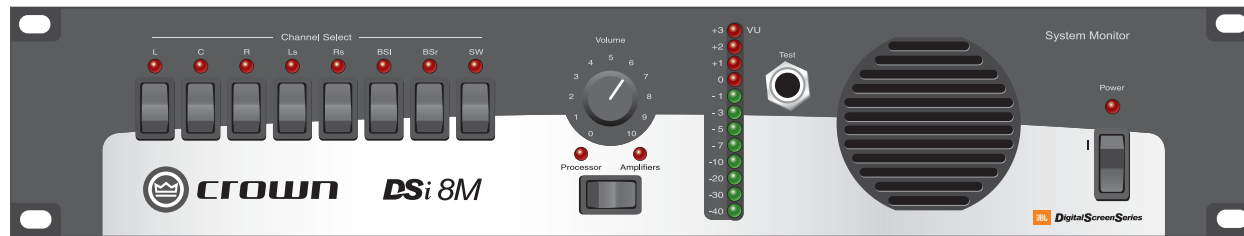

DSi 8M Cinema System Monitor

Operation Manual



Obtaining Other Language Versions: To obtain information in another language about the use of this product, please contact your local Crown Distributor. If you need assistance locating your local distributor, please contact Crown at 574-294-8000.

This manual does not include all of the details of design, production, or variations of the equipment. Nor does it cover every possible situation which may arise during installation, operation or maintenance.

The information provided in this manual was deemed accurate as of the publication date. However, updates to this information may have occurred. To obtain the latest version of this manual, please visit the Crown website at www.crownaudio.com.

Trademark Notice: Crown, Crown Audio, Amcron and IOC are registered trademarks of Crown International. Other trademarks are the property of their respective owners.

Some models may be exported under the name Amcron.®

©2008 by Crown Audio® Inc., 1718 W. Mishawaka Rd., Elkhart, Indiana 46517-9439 U.S.A. Telephone: 574-294-8000

H A Harman International Company

140094-2

3/08

Important Safety Instructions

Importantes Instrucciones de Seguridad

- 1) Read these instructions.
- 2) Keep these instructions.
- 3) Heed all warnings.
- 4) Follow all instructions.
- 5) Do not use this apparatus near water.
- 6) Clean only with a dry cloth.
- 7) Do not block any ventilation openings. Install in accordance with the manufacturer's instructions.
- 8) Do not install near any heat sources such as radiators, heat registers, stoves, or other apparatus (including amplifiers) that produce heat.
- 9) Do not defeat the safety purpose of the polarized or grounding-type plug. A polarized plug has two blades with one wider than the other. A grounding-type plug has two blades and a third grounding prong. The wide blade or the third prong is provided for your safety. If the provided plug does not fit into your outlet, consult an electrician for replacement of the obsolete outlet.
- 10) Protect the power cord from being walked on or pinched, particularly at plugs, convenience receptacles, and the point where they exit from the apparatus.
- 11) Only use attachments/accessories specified by the manufacturer.
- 12) Use only with a cart, stand, tripod, bracket, or table specified by the manufacturer, or sold with the apparatus. When a cart is used, use caution when moving the cart/apparatus combination to avoid injury from tip-over.
- 13) Unplug this apparatus during lightning storms or when unused for long periods of time.
- 14) Refer all servicing to qualified service personnel. Servicing is required when the apparatus has been damaged in any way, such as power-supply cord or plug is damaged, liquid has been spilled or objects have fallen into the apparatus, the apparatus has been exposed to rain or moisture, does not operate normally, or has been dropped.
- 15) Use the mains plug to disconnect the apparatus from the mains.
- 16) **WARNING: TO REDUCE THE RISK OF FIRE OR ELECTRIC SHOCK, DO NOT EXPOSE THIS APPARATUS TO RAIN OR MOISTURE.**
- 17) **DO NOT EXPOSE THIS EQUIPMENT TO DRIPPING OR SPLASHING AND ENSURE THAT NO OBJECTS FILLED WITH LIQUIDS, SUCH AS VASES, ARE PLACED ON THE EQUIPMENT.**
- 18) **THE MAINS PLUG OF THE POWER SUPPLY CORD SHALL REMAIN READILY OPERABLE.**



Wichtige Sicherheitsinstruktionen

Instrucciones de Seguridad Importantes

TO PREVENT ELECTRIC SHOCK DO NOT REMOVE TOP OR BOTTOM COVERS. NO USER SERVICEABLE PARTS INSIDE. REFER SERVICING TO QUALIFIED SERVICE PERSONNEL.

À PRÉVENIR LE CHOC ÉLECTRIQUE N'ENLEVEZ PAS LES COUVERCLES. IL N'Y A PAS DES PARTIES SERVICEABLE À L'INTÉRIEUR. TOUTS REPARATIONS DOIT ÊTRE FAIRE PAR PERSONNEL QUALIFIÉ SEULMENT.

PARA PREVENIR UN CHOQUE ELÉCTRICO, NO RETIRE LAS CUBIERTAS SUPERIOR O INFERIOR. NO EXISTEN PARTES QUE PUEDAN SER REPARADAS POR EL USUARIO AL INTERIOR. REMITA EL SERVICIO AL PERSONAL TÉCNICAL CALIFICADO.

TO COMPLETELY DISCONNECT THIS EQUIPMENT FROM THE AC MAINS, DISCONNECT THE POWER SUPPLY CORD PLUG FROM THE AC RECEPTACLE. THE MAINS PLUG OF THE POWER SUPPLY CORD SHALL REMAIN READILY OPERABLE.

POUR DÉMONTER COMPLÈTEMENT L'ÉQUIPEMENT DE L'ALIMENTATION GÉNÉRALE, DÉMONTER LE CÂBLE D'ALIMENTATION DE SON RÉCEPTACLE. LA PRISE D'ALIMENTATION RESTERA AISÉMENT FONCTIONNELLE.

PARA DESCONECTAR COMPLETAMENTE EL EQUIPO DEL SUMINISTRO ELECTRICO, DESCONECTE EL CABLE DE ALIMENTACION DE LA TOMA DE CA. LAS PATAS DEL CONECTOR DEL CABLE DE ALIMENTACION DEBERAN MANTENERSE EN BUEN ESTADO.

WATCH FOR THESE SYMBOLS:

The lightning bolt triangle is used to alert the user to the risk of electric shock.

The exclamation point triangle is used to alert the user to important operating or maintenance instructions.

REGARDEZ CES SYMBOLES

La triangle avec le sigle "foudre" est employée pour alerter l'utilisateur au risque de décharge électrique. Le triangle avec un point d'exclamation est employée pour alerter l'utilisateur d'instruction importantes pour lors opérations de maintenance.

ATENCION CON ESTOS SÍMBOLOS

El triángulo con el símbolo de rayo eléctrico es usado para alertar al usuario de el riesgo de un choque eléctrico.

El triángulo con el signo de admiración es usado para alertar al usuario de instrucciones importantes de operación o mantenimiento.



CAUTION
RISK OF ELECTRIC SHOCK
DO NOT OPEN



AVIS
RISQUE DE CHOC ÉLECTRIQUE
N'OUVREZ PAS



MAGNETIC FIELD

CAUTION! Do not locate sensitive high-gain equipment such as preamplifiers or tape decks directly above or below the unit. Because this amplifier has a high power density, it has a strong magnetic field which can induce hum into unshielded devices that are located nearby. The field is strongest just above and below the unit.

If an equipment rack is used, we recommend locating the amplifier(s) in the bottom of the rack and the preamplifier or other sensitive equipment at the top.

FCC COMPLIANCE NOTICE

This device complies with part 15 of the FCC rules. Operation is subject to the following two conditions: (1) This device may not cause harmful interference, and (2) this device must accept any interference received, including interference that may cause undesired operation.

CAUTION: Changes or modifications not expressly approved by the party responsible for compliance could void the user's authority to operate the equipment.

NOTE: This equipment has been tested and found to comply with the limits for a Class A digital device, pursuant to part 15 of the FCC Rules. These limits are designed to provide reasonable protection against harmful interference in a residential installation. This equipment generates, uses, and can radiate radio frequency energy and, if not installed and used in accordance with the instruction manual, may cause harmful interference to radio communications. However, there is no guarantee that interference will not occur in a particular installation. If this equipment does cause harmful interference to radio or television reception, which can be determined by turning the equipment off and on, the user is encouraged to try to correct the interference by one or more of the following measures:

- Reorient or relocate the receiving antenna.
- Increase the separation between the equipment and receiver.
- Connect the equipment into an outlet on a circuit different from that to which the receiver is connected.
- Consult the dealer or an experienced radio/TV technician for help.

Crown Audio, Inc.

DECLARATION of CONFORMITY

Issued By: Crown Audio, Inc.
1718 W. Mishawaka Rd.
Elkhart, IN 46517

COMPLIANCE QUESTIONS ONLY: Sue Whitfield
574-294-8289
swhitfield@crowntl.com

European Representative's Name and Address:

David Budge
10 Harvest Close
Yateley GU46 6YS
United Kingdom

Equipment Type: Commercial Audio Processors

Family Name: DSi family

Model Names: DSi 8M

EMC Standards:

EN 55103-1:1997 Electromagnetic Compatibility - Product Family Standard for Audio, Video, Audio-Visual and Entertainment Lighting Control Apparatus for Professional Use, Part 1: Emissions

EN 55103-1:1997 Magnetic Field Emissions-Annex A @ 10 cm and 20 cm

EN 61000-3-2:2001 Limits for Harmonic Current Emissions (equipment input current less than or equal to 16 A per phase)

EN 61000-3-3:2002 Limitation of Voltage Fluctuations and Flicker in Low-Voltage Supply Systems Rated Current less than or equal to 16A

EN 55022:2003 Limits and Methods of Measurement of Radio Disturbance Characteristics of ITE: Radiated, Class B Limits; Conducted, Class A

EN 55103-2:1997 Electromagnetic Compatibility - Product Family Standard for Audio, Video, Audio-Visual and Entertainment Lighting Control Apparatus for Professional Use, Part 2: Immunity

EN 61000-4-2:2001 Electrostatic Discharge Immunity (Environment E2-Criteria B, 4k V Contact, 8k V Air Discharge)

EN 61000-4-3:2001 Radiated, Radio-Frequency, Electromagnetic Immunity (Environment E2, criteria A)

EN 61000-4-4:2001 Electrical Fast Transient/Burst Immunity (Criteria B)

EN 61000-4-5:2001 Surge Immunity (Criteria B)

EN 61000-4-6:2003 Immunity to Conducted Disturbances Induced by Radio-Frequency Fields (Criteria A)

EN 61000-4-11:2001 Voltage Dips, Short Interruptions and Voltage Variation

Safety Standard:

IEC 60065: 2001 7th Ed. Safety Requirements - Audio Video and Similar Electronic Apparatus

I certify that the product identified above conforms to the requirements of the EMC Council Directive 89/336/EEC as amended by 92/31/EEC, and the Low Voltage Directive 73/23/EES as amended by 93/68/EEC.

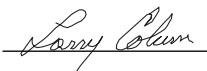
Signed 

Larry Coburn
Title: Senior Vice President of Manufacturing

Date of Issue: Jan. 31, 2007

Table of Contents

Table of Contents

FCC Compliance Notice	2
Declaration of Conformity	3
1 Welcome	5
1.1 Features	5
1.2 Unpacking	5
2 Controls, Indicators and Connectors	6
2.1 Front Panel Controls, Indicators and Connectors	6
2.2 Rear Panel Controls and Connectors	7
3 Installation	8
3.1 Materials Required	8
3.2 Mount the DSi 8M	8
3.3 Monitor Wiring	8
4 Operation	13
4.1 Setting Monitor and Bargraph Levels	13
5 Specifications	13
6 Service	14
6.1 International and Canada Service	14
6.2 US Service	14
6.2.1 Service at a US Service Center	14
6.2.2 Factory Service	14
6.2.3 Factory Service Shipping Instructions	14
6.2.4 Packing Instructions	14
6.2.5 Estimate Approval	14
6.2.6 Payment of Non-Warranty Repairs	14
7 Warranty	15
Product Registration Form	17
Factory Service Information Form	19

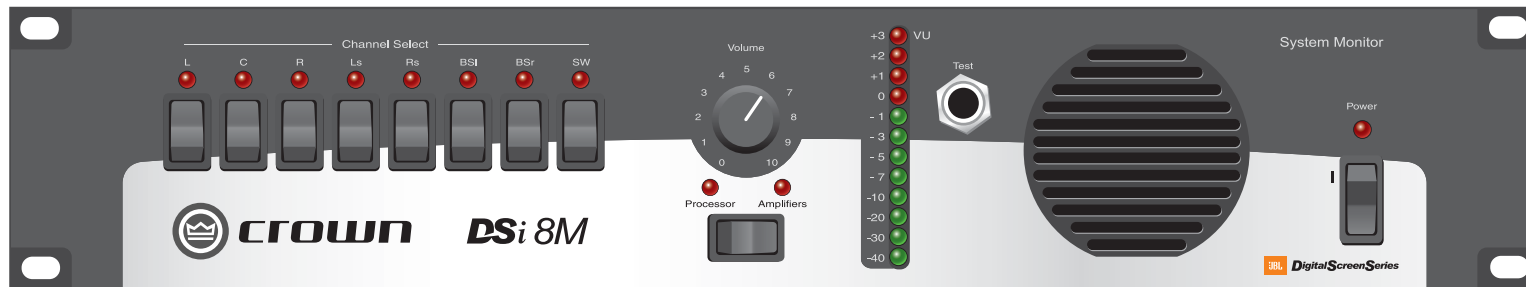

1 Welcome

Please read this entire manual before beginning your installation.

The Crown® DSi 8M is a projection booth monitor for cinema applications. It has been designed for high performance, ease of use and years of trouble-free service.

All controls necessary for daily operation of the DSi 8M are easily accessible on the front panel. 8-channel monitoring allows you to monitor either the inputs from the cinema processor or the power amplifier's outputs: L, C, R, Ls, Rs, Bsl, Bsr, and Sub in any combination.

On the back panel are Phoenix connectors and HD-15 connectors for quick connection to power amplifiers. Inputs and outputs are balanced. The unit is equipped with an internal universal power supply.

No special tools are required for installation. The built-in VU meter and test jack give the technician immediate information about the status of the DSi 8M and all power amplifiers.

Your investment in a DSi-Series product is backed by Crown's Three-Year, No-Fault, Fully Transferable Warranty.

1.1 Features

- Compact 2-rack unit
- 8 channels for monitoring processor or amplifier inputs
- All inputs and outputs are balanced to interface with new cinema processors
- Input levels for processor and power amps can be adjusted independently
- No level jumps when switching between processor and amplifiers
- Bargraph display may be calibrated to the reference level for your theater; projectionist sees auditorium levels instantly
- 25-pin D-sub connectors, plus removable terminal blocks and HD-15 connectors for quick, hassle-free connections
- Designed to work with bi-amplified sound systems to monitor the high- and low-frequency outputs from the left, center and right channels
- Three-Year, No-Fault, Fully Transferable Warranty completely protects your investment and guarantees its specifications

1.2 Unpacking

Please unpack and inspect your DSi 8M Monitor for any damage that may have occurred during transit. If damage is found, notify the transportation company immediately. Only you can initiate a claim for shipping damage. Crown will be happy to help as needed. Save the shipping carton as evidence of damage for the shipper's inspection.

We also recommend that you save all packing materials so you will have them if you ever need to transport the unit. **Never ship the unit without the factory pack.**

2 Controls, Indicators and Connectors

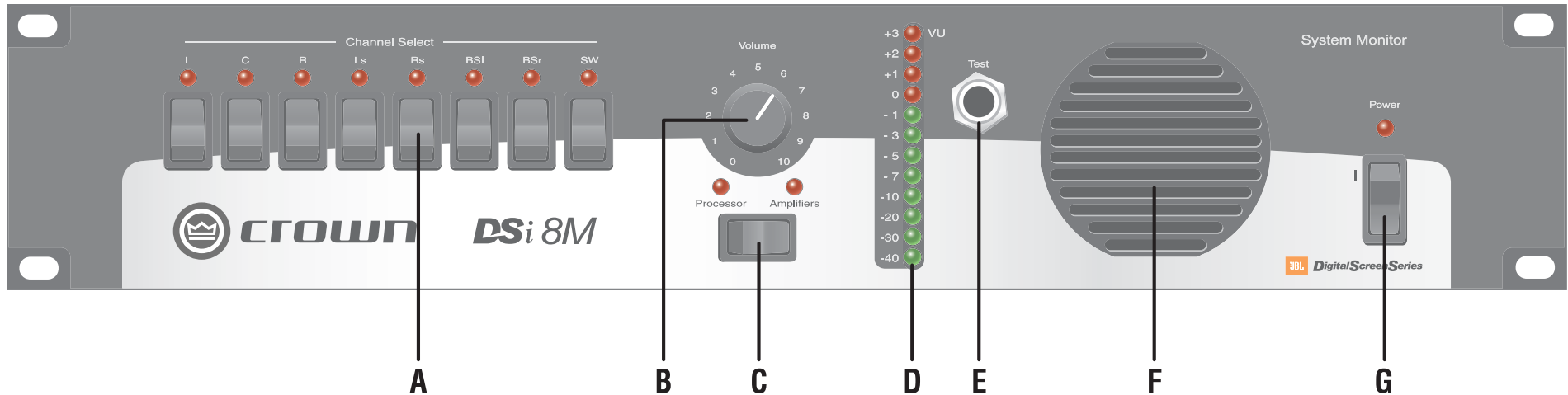

Figure 2.1 Front Panel Controls, Indicators and Connectors

2.1 Front Panel Controls, Indicators and Connectors

A. Channel Select Buttons and LEDs

Eight pushbutton switches, one for each input channel. Pressing a button monitors the signal from that channel, and lights the corresponding LED. Any combination of eight channels can be selected.

B. Volume Control

Rotary potentiometer with knob controls the volume of the internal or external speaker. Has no effect on the VU Bargraph Meter display.

C. Processor/Amplifier Selector Switch and LEDs

Pushbutton switch with corresponding LEDs selects inputs from cinema processor or power amplifiers for monitoring.

D: VU Bargraph Meter

12-segment meter displays input level of selected channels from -40 VU to $+3$ VU. The meter can be calibrated by the rear-panel trim adjustment, which operates independently of the Volume Control.

E. Test Jack

1/4" phone jack lets the user monitor the audio output of the DSi 8M. Inserting a mono or stereo 1/4" phone plug here disables the internal speaker and routes the audio output to the Test Jack.

F. Internal Speaker

For convenient monitoring at the monitor panel.

G. Power Switch and Power LED

Rocker switch turns power on or off. LED illuminates when power is on.

The DSi 8M is intended to be used with DSi Series amplifiers which use on-board crossovers for any loudspeaker application. Therefore, there is no internal crossover option for the DSi 8M System Monitor.

2 Controls, Indicators and Connectors

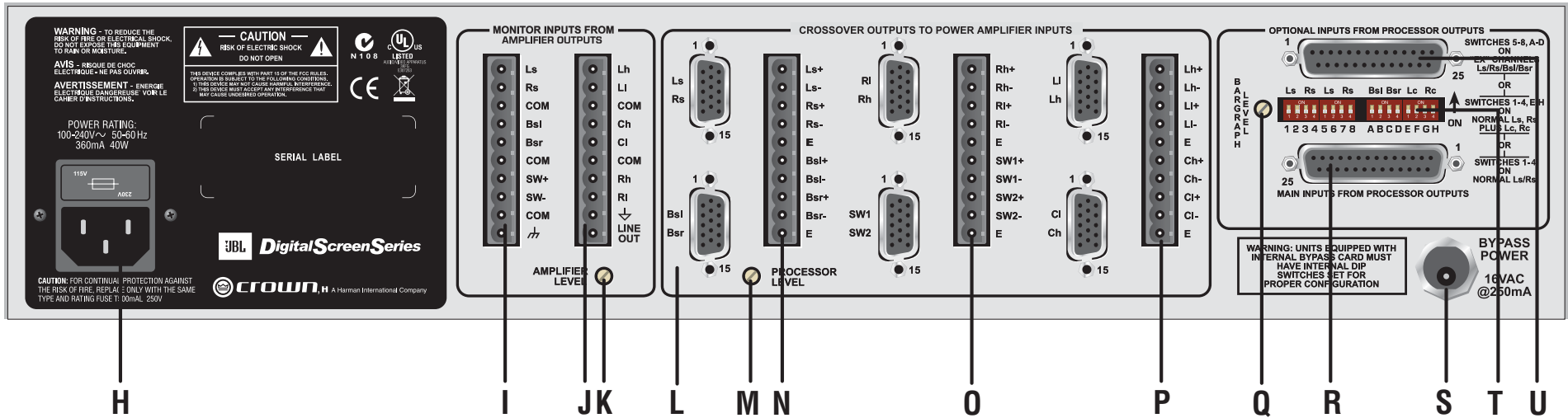

Figure 2.2 Rear Panel Controls and Connectors

2.2 Rear Panel Controls and Connectors

H. IEC AC Power Receptacle

Connects to an IEC AC power cord.

I. Input Connector

10-pin Phoenix terminal block connects to the power amplifier speaker outputs for the Left Surround, Right Surround, Back Surround Left, Back Surround Right and Subwoofer channels. This connector lets you monitor the output of amplifiers that do not include HD-15 connector options.

J. Input Connector

10-pin Phoenix terminal block connects to the power amplifier speaker output for the Left High, Left Low, Center High, Center Low, Right High and Right Low channels. This connector lets you monitor the output of amplifiers that do not include HD-15 connector options.

K. Amplifier Level Control

Trimpot adjusts the level of the input signals from the power amplifiers.

L. Outputs to Power Amplifier Inputs

The six HD-15 connectors in this section connect to DSi amplifiers for both input and output signals. The HD-15 connectors have two functions:

1. Connect DSi 8M outputs to DSi amplifier inputs.
2. Connect DSi amplifier outputs to DSi 8M inputs for monitoring.

Using VGA cables, the HD-15 connectors can be connected to Crown DSi power amplifier HD-15 connectors as described below.

- HD-15 Connector 1:** Connects to Left Surround/Right Surround amplifier.
- HD-15 Connector 2:** Connects to Back Surround Left/Back Surround Right amplifier.
- HD-15 Connector 3:** Connects to Right Low/Right High amplifier.
- HD-15 Connector 4:** Connects to Subwoofer amplifier.
- HD-15 Connector 5:** Connects to Left Low/Left High amplifier.
- HD-15 Connector 6:** Connects to Center Low/Center High amplifier.

M. Processor Level

Trimpot adjusts the level of the input signals from the cinema processor.

N. Surround Output Connector

10-pin Phoenix terminal block connects to the power amplifier inputs for Left Surround, Right Surround, Back Surround Left and Back Surround Right channels.

O. Right-Channel and Subwoofer Output Connector

10-pin Phoenix terminal block connects to the power amplifier inputs for Right Low, Right High and Subwoofer channels.

P. Left-Channel and Center Output Connector

10-pin Phoenix terminal block connects to the power amplifier inputs for Left Low/Left High and Center Low/Center High channels.

Q. Bargraph Level

Trimpot adjusts the sensitivity of the front-panel VU Bargraph Meter.

R. Main Input Connector

25-pin D-sub connector connects to the main outputs of the cinema processor.

S. AC Emergency Power Input Connector

Connects to 12-16VAC, 0.5A source.

T. "EX" Selector Switch

8-position DIP switch. Turn on switches 1-4 if system is without EX. Turn on switches 5-8 if system is with EX. This routes the correct Left-Surround/Right-Surround inputs to the DSi 8M circuitry.

U. Optional Input Connector

25-pin D-sub connector connects to the EX output of the processor.

3 Installation

3.1 Materials Required

You will need to supply the following materials:

- Shielded audio cable for connecting the DSi 8M to the cinema processor and power amplifier inputs
- Twisted wire for connecting the DSi 8M to non-DSi power-amplifier outputs
- Four 10-32 x 1/2" screws to mount the DSi 8M in the audio equipment rack
- Small standard screwdriver
- No. 2 Philips screwdriver
- Wire strippers

3.2 Mount the DSi 8M

The ideal place for the DSi 8M Monitor Panel is in the sound rack or projector console between the stereo processor and power amplifiers. DB25 and HD15 connectors are available on the back panel to make installation quick and easy. Alternatively, terminal blocks allow the use of stripped and tinned wire. They are pluggable for easy service and troubleshooting.

3.3 Monitor Wiring

1. Connect to AC Power.

Connect the unit to the AC power outlet using the standard IEC cable provided. Any power source from 100-240V, 50-60 Hz will be sufficient. Plug the Modular Power Supply into the Bypass Power input and into a power source that matches the Modular Power Supply requirements.
(continued)

3 Installation (continued)

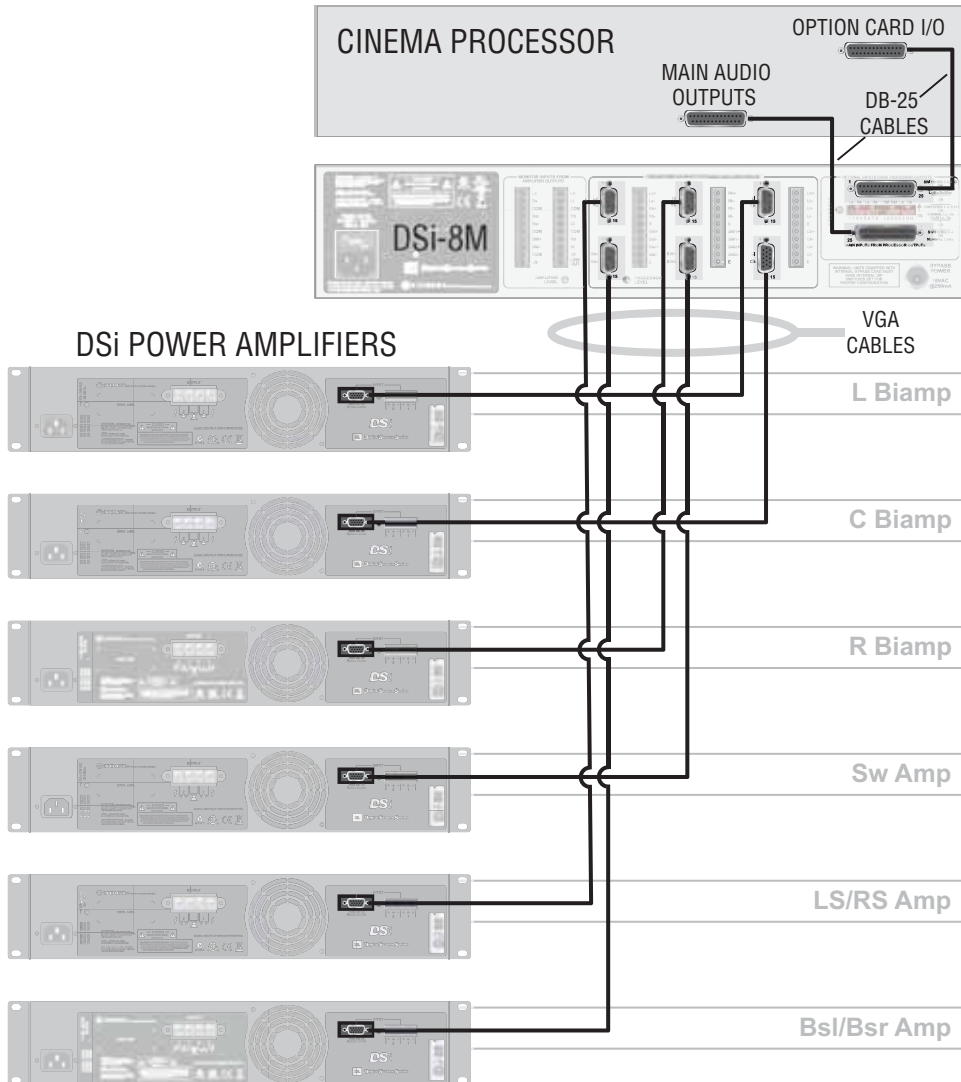

Figure 3.1 Wiring DSi 8M Monitor Panel to DSi Amplifiers

2. Connect cinema processor output to DSi 8M input.

See Figure 3-1. Use the male-female 25-pin D cable to connect the output of the cinema processor to the Main input of the DSi 8M. If "EX" channels are to be used, plug an additional male-female 25-pin D cable from the **Optional Outputs** at the processor to the **Optional Inputs** of the DSi 8M.

3. Make DIP switch settings.

Ls/Rs in Main Connector: Set switches 1-4 ON, 5-8 OFF.

Ls/Rs in Optional Connector: Set switches 5-8 ON, 1-4 OFF.

USL JSD-80 processor using:

Bsl/Bsr in Main Connector: Set switches A-D ON, E-O OFF.

Lc/Rc in Main Connector: Set switches A-O OFF.

Lc/Rc and/or Bsl/Bsr in Optional Connector: Set switches E-H ON, A-D OFF, J-O OFF.

Dolby® CP-650 processor using:

Le/Re in Optional Connector: Set switches E-H ON, A-D OFF, J-O OFF.

Lm/Cm/Rm in Optional Connector: Set switches J-O ON, A-H OFF.

3 Installation (continued)

4. Connect DSi 8M outputs either to DSi power amplifiers or to active-crossover inputs.

Option 1 – Connecting to DSi amplifiers

If you have Crown DSi power amplifiers, connect the DSi 8M HD-15 outputs to the HD-15 connectors on the DSi amplifiers as in Figures 3.1 and 3.2. Full-range signals are sent from each DSi 8M HD-15 I/O connector.

To simplify wiring, the DSi amplifier has built-in presets that determine signal routing. Section 4, Table 1 of the DSi Series Operation Manual shows all the available presets. In this example, the DSi 1000 amplifier is set to the JBL 3632 preset, which is a highpass filter for the JBL 3632 MF and HF drivers, and a lowpass filter for the JBL 3632 LF drivers.

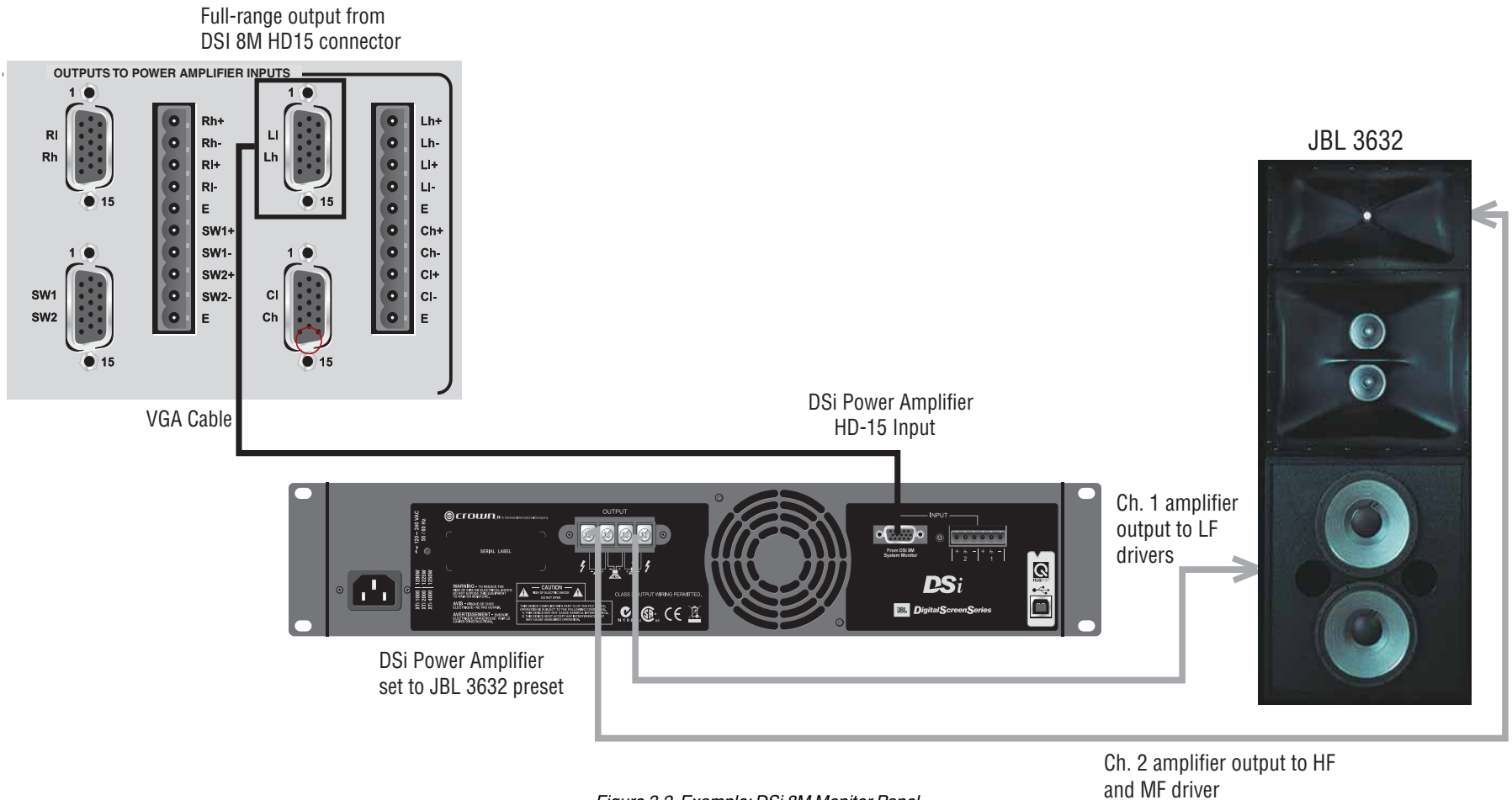

Figure 3.2 Example: DSi 8M Monitor Panel and DSi Amplifier Wired for Bi-amped Operation

3 Installation (continued)

Option 2 – Connecting the DSi 8M to amplifiers other than the DSi Series

If you have power amplifiers other than the DSi series, you need an active crossover. Figure 3.3 shows an example of a bi-amped system with an active crossover.

The DSi 8M left-low (full-range) terminals are connected to the active crossover input. The crossover outputs are connected to the power amplifier inputs, and the amplifier outputs are connected to the loudspeaker.

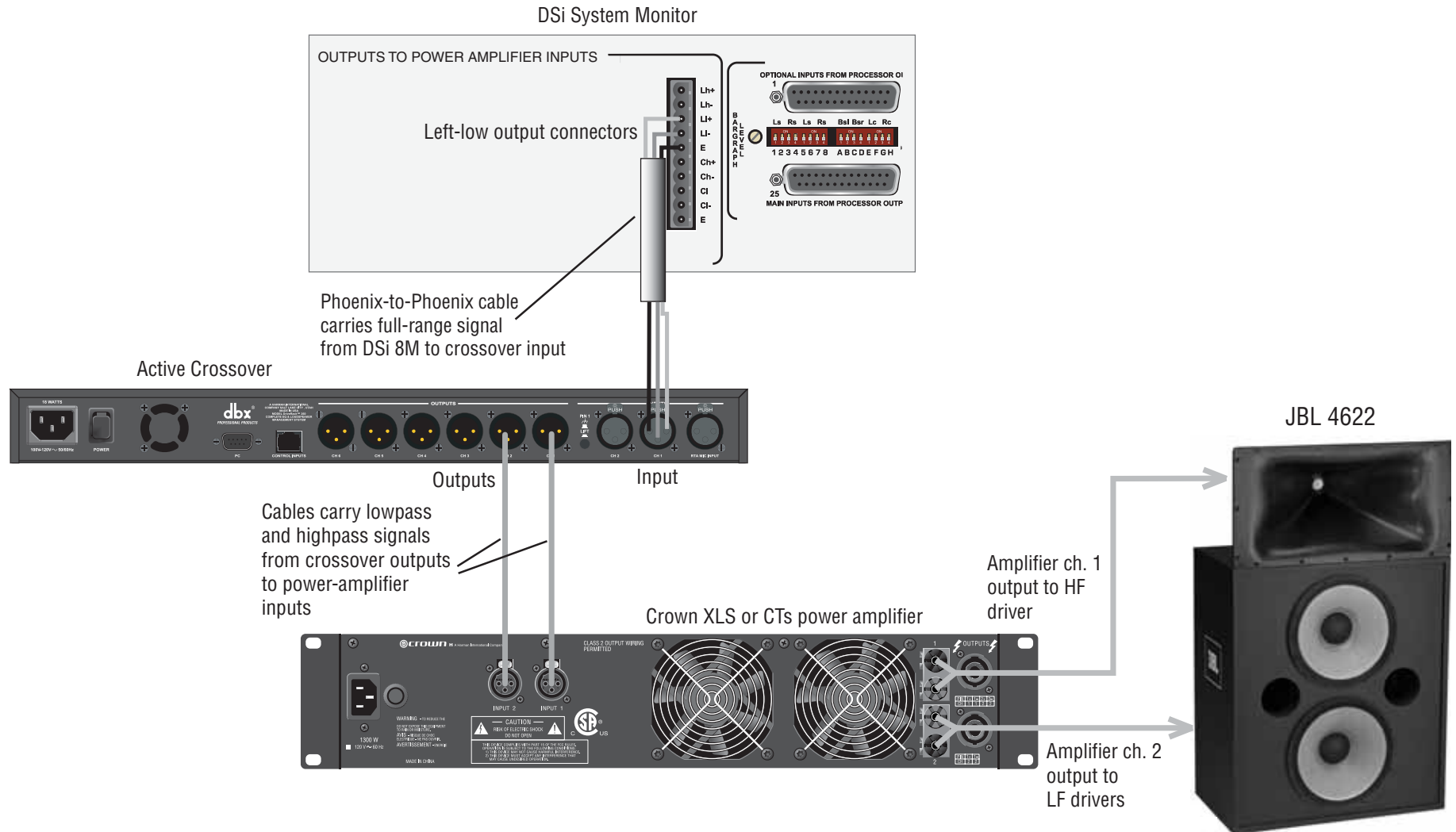

Figure 3.3 Example of Bi-amped Operation Using an Active Crossover and a Non-DSi Power Amplifier

3 Installation (continued)

5. Connecting DSi 8M inputs to power amplifier outputs: two options

Option 1: If you have Crown DSi power amplifiers, use six VGA cables as shown in Figure 3.1 and Figure 3.4.

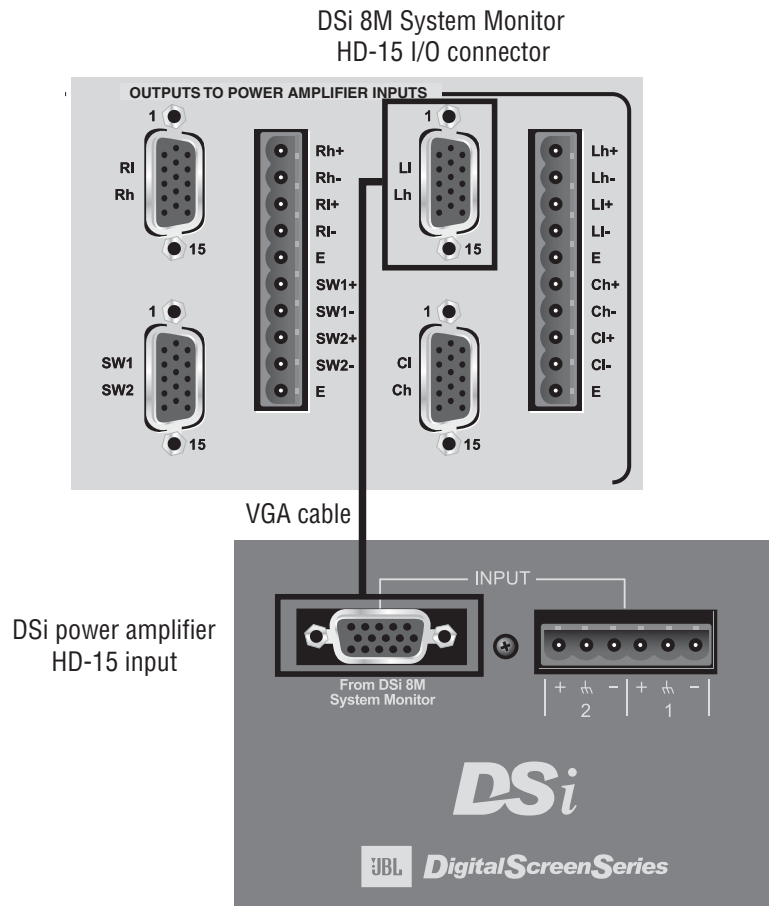

Figure 3.4 Connection to Monitor the DSi Power Amplifier Output

Option 2: Connect the amplifier loudspeaker outputs to the DSi 8M's Phoenix input connectors I and J as shown in Figure 3.5. Unshielded wire can be used. Section 5 gives the connector pin assignments.

All the inputs on the rear panel are unbalanced except for the subwoofer input.

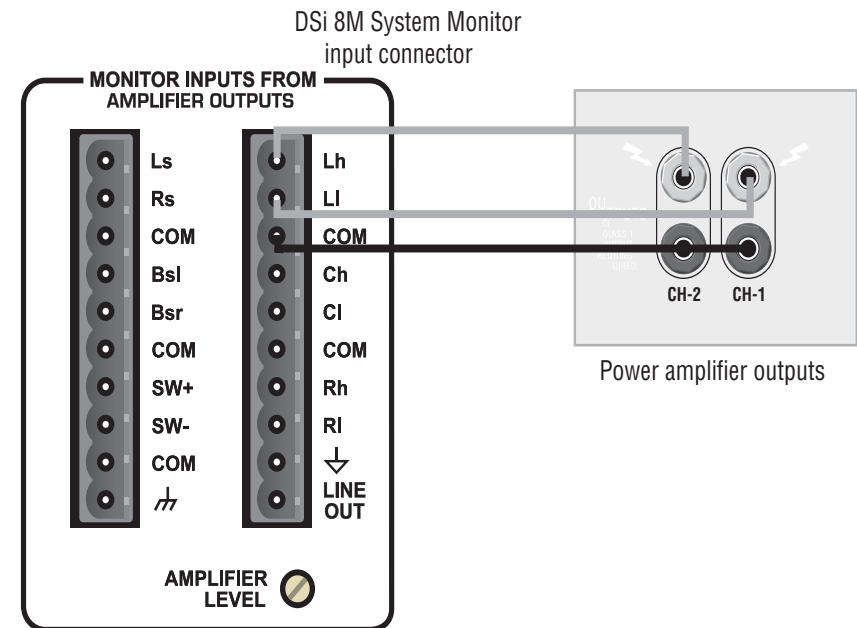

Figure 3.5 Using Phoenix Connectors with Non-DSi Amplifiers

4 Operation

4.1 Setting Monitor and Bargraph Levels

1. Set the cinema processor main fader and amplifier levels so the house speakers are playing back at the normal listening level. Select some source material like pink noise.

2. On the DSi 8M, set the Processor/Amplifier Switch to "Processor." With the monitor volume set at 7, adjust the Processor Trimpot for a comfortable listening level. Set the Bargraph Trimpot for a reading in the middle range.

3. On the DSi 8M, set the Processor/Amplifier Switch to "Amplifier." Adjust the amplifier trimpot so the level matches the processor level.

5 Specifications

Processor Inputs: Eight inputs for the left, center, right, surround left, surround right, back surround left, back surround right, and subwoofer channels.

Power Amplifiers Inputs: Eleven inputs for left high and low, center high and low, right high and low, surround left, surround right, back surround left, back surround right, and subwoofer channels.

Input Impedance (Processor Inputs): 10 k ohms.

Input Impedance (Power Amplifiers Inputs): > 50 k ohms.

Power Requirements: 100-240V \sim 50-60 Hz, 32 watts.

Chassis: Steel.

Dimensions: EIA Standard 19-inch rack mount width (EIA RS-310-B), 3.5 inches (8.9 cm) high and 9.625 inches (24.4 cm) deep behind front mounting surface.

Net Weight: 10 lb 2 oz (4.63 kg).

Shipping Weight: 16 lb (7.26 kg).

10 PIN PHOENIX DSi 8M INPUTS FROM AMPLIFIER OUTPUTS

1. Left surround
2. Right surround
3. Common
4. Back surround left
5. Back surround right
6. Common
7. Subwoofer +
8. Subwoofer -
9. Common
10. Chassis ground

1. Left high
2. Left low
3. Common
4. Center high
5. Center low
6. Common
7. Right high
8. Right low
9. Signal ground
10. Line output

10 PIN PHOENIX DSi 8M OUTPUTS TO POWER AMPLIFIER INPUTS

1. Left surround +
2. Left surround -
3. Right surround +
4. Right surround -
5. Common
6. Back surround left +
7. Back surround left -
8. Back surround right +
9. Back surround right -
10. Common

1. No connect
2. No connect
3. Right +
4. Right -
5. Common
6. Subwoofer +
7. Subwoofer -
8. No connect
9. No connect
10. Common

1. No connect
2. No connect
3. Left +
4. Left -
5. Common
6. No connect
7. No connect
8. Center +
9. Center -
10. Common

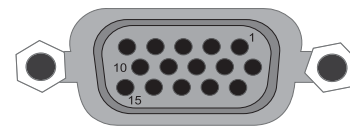

PIN	PIN
1 Ch1 Inverting Input	9 NC
2 NC	10 Signal Ground
3 Ch1 Output Voltage Monitor	11 Ch2 Inverting Input
4 NC	12 NC
5 NC	13 Ch2 Output Voltage Monitor
6 Chassis Ground	14 NC
7 Ch1 Non-Inverting Input	15 NC
8 Ch2 Non-Inverting Input	

Figure 5.1 HD-15 Connector Pinout

DB-25 Connector Pinout

N/C = no connect

Pin #	Main Processor Outputs	Optional Processor Outputs
1	GND	N/C
2	L +	N/C
3	N/C	Bsl -
4	GND	N/C
5	C +	Ch +
6	N/C	Bsr -
7	GND	GND
8	R +	Rh +
9	GND	N/C
10	LS -	Ls -
11	RS -	Rs -
12	SW -	Lh -
13	GND	N/C
14	L -	N/C
15	N/C	N/C
16	N/C	Bsl +
17	C -	Ch -
18	N/C	N/C
19	N/C	Bsr +
20	R -	Rh -
21	N/C	N/C
22	GND	N/C
23	LS +	Ls +
24	RS +	Rs +
25	SW +	Lh +

6 Service

Crown products are quality units that rarely require servicing. Before returning your unit for service, please contact Crown Technical Support to verify the need for servicing.

This unit has very sophisticated circuitry which should only be serviced by a fully trained technician. This is one reason why each unit bears the following label:



CAUTION: To prevent electric shock, do not remove covers. No user serviceable parts inside. Refer servicing to a qualified technician.

Complete the Crown Audio Factory Service Information form, in the back of this manual, when returning a Crown product to the factory or authorized service center. The form must be included with your product inside the box or in a packing slip envelope securely attached to the outside of the shipping carton. Do not send this form separately.

Warranty is only valid within the country in which the product is purchased.

6.1 International and Canada Service

Service may be obtained from an authorized service center. (Contact your local Crown/Amcron representative or our office for a list of authorized service centers.) To obtain service, simply present the bill of sale as proof of purchase along with the defective unit to an authorized service center. They will handle the necessary paperwork and repair.

Remember to transport your unit in the original factory pack.

6.2 US Service

Service may be obtained in one of two ways: from an authorized service center or from the factory. You may choose either. It is important that you have your copy of the bill of sale as your proof of purchase.

6.2.1 Service at a US Service Center

This method usually saves the most time and effort. Simply present your bill of sale along with the defective unit to an authorized service center to obtain service. They will handle the necessary paperwork and repair.

Remember to transport the unit in the original factory

pack. A list of authorized service centers in your area can be obtained from Crown Factory Service, or online from <http://www.crownaudio.com/support/servcent.htm>.

6.2.2 Factory Service

Crown accepts no responsibility for non-serviceable product that is sent to us for factory repair. It is the owner's responsibility to ensure that their product is serviceable prior to sending it to the factory. Serviceable product list is available at <http://crownweb.crownintl.com/crownrma/>. For more information, please contact us direct.

A Service Return Authorization (SRA) is required for product being sent to the factory for repair. An SRA can be completed online at www.crownaudio.com/support/factserv.htm. If you do not have access to the web, please call Crown's Customer Service at 574.294.8200 or 800.342.6939 extension 8205.

For warranty service, we will pay for ground shipping both ways in the United States. Contact Crown Customer Service to obtain prepaid shipping labels prior to sending the unit. Or, if you prefer, you may prepay the cost of shipping, and Crown will reimburse you. Send copies of the shipping receipts to Crown to receive reimbursement. Your repaired unit will be returned via UPS ground. Please contact us if other arrangements are required.

6.2.3 Factory Service Shipping Instructions:

1. Service Return Authorization (SRA) is required for product being sent to the factory for service. Please complete the SRA by going to www.crownaudio.com/support/factserv.htm. If you do not have access to our website, call 1.800.342.6939, extension 8205 and we'll create the SRA for you.
2. See packing instructions that follow.
3. Ship product to:
CROWN AUDIO FACTORY SERVICE
1718 W MISHAWKA RD.
ELKHART, IN 46517
4. Use a bold black marker and write the SRA number on three sides of the box.

5. Record the SRA number for future reference. The SRA number can be used to check the repair status.

6.2.4 Packing Instructions

Important: These instructions must be followed. If they are not followed, Crown Audio, Inc. assumes no responsibility for damaged goods and/or accessories that are sent with your unit.

1. Fill out and include the Crown Audio Factory Service Information sheet in the back of this manual.
2. Do not ship any accessories (manuals, cords, hardware, etc.) with your unit. These items are not needed to service your product. We will not be responsible for these items.
3. When shipping your Crown product, it is important that it has adequate protection. We recommend you use the original pack material when returning the product for repair. If you do not have the original box, please call Crown at 800.342.6939 or 574.294.8210 and order new pack material. See instructions for "foam-in-place" shipping pack. (Do not ship your unit in a wood or metal cabinet.)
4. If you provide your own shipping pack, the minimum recommended requirements for materials are as follows:
 - a. 275 P.S.I. burst test, Double-Wall carton that allows for 2-inch solid Styrofoam on all six sides of unit or 3 inches of plastic bubble wrap on all six sides of unit.
 - b. Securely seal the package with an adequate carton sealing tape.
 - c. Do not use light boxes or "peanuts". Damage caused by poor packaging will not be covered under warranty.

Using your foam-in-place shipping pack

Note: The foam-in-place packing is molded so that there is only one correct position for your product.

1. Open carton and lift center cushion leaving both end-cushions in place.

2. Carefully place your product with the product's front panel facing the same direction as arrows indicate.
3. Reset center cushion down over top of product's chassis. The foam-in-place packing was molded to accommodate different chassis depth sizes. If your product's chassis does not completely fill the foam-in-place cavity, you may use a soft but solid packing material (such as paper or bubble wrap) behind the chassis.
4. Enclose the completed Crown Audio Factory Service Information form (or securely attach it to the outside of carton) and re-seal the shipping pack with a sturdy carton sealing tape.

6.2.5 Estimate Approval

Approval of estimate must be given within 30 days after being notified by Crown Audio Inc. Units still in the possession of Crown after 30 days of the estimate will become the property of Crown Audio Inc.

6.2.6 Payment of Non-Warranty Repairs

Payment on out-of-warranty repairs must be received within 30 days of the repair date. Units unclaimed after 30 days become the property of Crown Audio Inc.

If you have any questions, please contact Crown Factory Service.

Crown Factory Service
1718 W. Mishawaka Rd.,
Elkhart, Indiana 46517 U.S.A.

Telephone:
574.294.8200
800.342.6939 (North America,
Puerto Rico, and Virgin Islands only)

Facsimile:
574.294.8301 (Technical Support)
574.294.8124 (Factory Service)

Internet:
<http://www.crownaudio.com>

7 Warranty



SUMMARY OF WARRANTY

Crown International, 1718 West Mishawaka Road, Elkhart, Indiana 46517-4095 U.S.A. warrants to you, the ORIGINAL PURCHASER and ANY SUBSEQUENT OWNER of each NEW Crown product, for a period of three (3) years from the date of purchase by the original purchaser (the "warranty period") that the new Crown product is free of defects in materials and workmanship. We further warrant the new Crown product regardless of the reason for failure, except as excluded in this Warranty.

Warranty is only valid within the country in which the product was purchased.

ITEMS EXCLUDED FROM THIS CROWN WARRANTY

This Crown Warranty is in effect only for failure of a new Crown product which occurred within the Warranty Period. It does not cover any product which has been damaged because of any intentional misuse, accident, negligence, or loss which is covered under any of your insurance contracts. This Crown Warranty also does not extend to the new Crown product if the serial number has been defaced, altered, or removed.

WHAT THE WARRANTOR WILL DO

We will remedy any defect, regardless of the reason for failure (except as excluded), by repair, replacement, or refund. We may not elect refund unless you agree, or unless we are unable to provide replacement, and repair is not practical or cannot be timely made. If a refund is elected, then

UNITED STATES & CANADA

you must make the defective or malfunctioning product available to us free and clear of all liens or other encumbrances. The refund will be equal to the actual purchase price, not including interest, insurance, closing costs, and other finance charges less a reasonable depreciation on the product from the date of original purchase. Warranty work can only be performed at our authorized service centers or at the factory. Warranty work for some products can only be performed at our factory. We will remedy the defect and ship the product from the service center or our factory within a reasonable time after receipt of the defective product at our authorized service center or our factory. All expenses in remedying the defect, including surface shipping costs in the United States, will be borne by us. (You must bear the expense of shipping the product between any foreign country and the port of entry in the United States including the return shipment, and all taxes, duties, and other customs fees for such foreign shipments.)

HOW TO OBTAIN WARRANTY SERVICE

You must notify us of your need for warranty service within the warranty period. All components must be shipped in a factory pack, which, if needed, may be obtained from us free of charge. Corrective action will be taken within a reasonable time of the date of receipt of the defective product by us or our authorized service center. If the repairs made by us or our authorized service center are not satisfactory, notify us or our authorized service center immediately.

DISCLAIMER OF CONSEQUENTIAL AND INCIDENTAL DAMAGES

YOU ARE NOT ENTITLED TO RECOVER FROM US ANY INCIDENTAL DAMAGES RESULTING FROM ANY DEFECT IN THE NEW CROWN PRODUCT. THIS INCLUDES ANY DAMAGE TO ANOTHER PRODUCT OR PRODUCTS RESULTING FROM SUCH A DEFECT. SOME STATES DO NOT ALLOW THE EXCLUSION OR LIMITATIONS OF INCIDENTAL OR CONSEQUENTIAL DAMAGES, SO THE ABOVE LIMITATION OR EXCLUSION MAY NOT APPLY TO YOU.

WARRANTY ALTERATIONS

No person has the authority to enlarge, amend, or modify this Crown Warranty. This Crown Warranty is not extended by the length of time which you are deprived of the use of the new Crown product. Repairs and replacement parts provided under the terms of this Crown Warranty shall carry only the unexpired portion of this Crown Warranty.

DESIGN CHANGES

We reserve the right to change the design of any product from time to time without notice and with no obligation to make corresponding changes in products previously manufactured.

LEGAL REMEDIES OF PURCHASER

THIS CROWN WARRANTY GIVES YOU SPECIFIC LEGAL RIGHTS, YOU MAY ALSO HAVE OTHER RIGHTS WHICH VARY FROM STATE TO STATE. No action to enforce this Crown Warranty shall be commenced after expiration of the warranty period.

THIS STATEMENT OF WARRANTY SUPERSEDES ANY OTHERS CONTAINED IN THIS MANUAL FOR CROWN PRODUCTS. 9/07

7 Warranty



SUMMARY OF WARRANTY

Crown International, 1718 West Mishawaka Road, Elkhart, Indiana 46517-4095 U.S.A. warrants to you, the ORIGINAL PURCHASER and ANY SUBSEQUENT OWNER of each NEW Crown1 product, for a period of three (3) years from the date of purchase by the original purchaser (the "warranty period") that the new Crown product is free of defects in materials and workmanship, and we further warrant the new Crown product regardless of the reason for failure, except as excluded in this Warranty.

Warranty is only valid within the country in which the product is purchased.

¹ Note: If your unit bears the name "Amcron," please substitute it for the name "Crown" in this warranty.

ITEMS EXCLUDED FROM THIS CROWN-WARRANTY

This Crown Warranty is in effect only for failure of a new Crown product which occurred within the Warranty Period. It does not cover any product which has been damaged because of any intentional misuse, accident, negligence, or loss which is covered under any of your insurance contracts. This Crown Warranty also does not extend to the new Crown product if the serial number has been defaced, altered, or removed.

WORLDWIDE EXCEPT USA & CANADA

WHAT THE WARRANTOR WILL DO

We will remedy any defect, regardless of the reason for failure (except as excluded), by repair, replacement, or refund. We may not elect refund unless you agree, or unless we are unable to provide replacement, and repair is not practical or cannot be timely made. If a refund is elected, then you must make the defective or malfunctioning product available to us free and clear of all liens or other encumbrances. The refund will be equal to the actual purchase price, not including interest, insurance, closing costs, and other finance charges less a reasonable depreciation on the product from the date of original purchase. Warranty work can only be performed at our authorized service centers. We will remedy the defect and ship the product from the service center within a reasonable time after receipt of the defective product at our authorized service center.

HOW TO OBTAIN WARRANTY SERVICE

You must notify your local Crown importer of your need for warranty service within the warranty period. All components must be shipped in the original box. Corrective action will be taken within a reasonable time of the date of receipt of the defective product by our authorized service center. If the repairs made by our authorized service center are not satisfactory, notify our authorized service center immediately.

DISCLAIMER OF CONSEQUENTIAL AND INCIDENTAL DAMAGES

YOU ARE NOT ENTITLED TO RECOVER FROM US ANY INCIDENTAL DAMAGES RESULTING FROM ANY DEFECT IN THE NEW CROWN PRODUCT. THIS INCLUDES ANY DAMAGE TO ANOTHER PRODUCT OR PRODUCTS RESULTING FROM SUCH A DEFECT.

WARRANTY ALTERATIONS

No person has the authority to enlarge, amend, or modify this Crown Warranty. This Crown Warranty is not extended by the length of time which you are deprived of the use of the new Crown product. Repairs and replacement parts provided under the terms of this Crown Warranty shall carry only the unexpired portion of this Crown Warranty.

DESIGN CHANGES

We reserve the right to change the design of any product from time to time without notice and with no obligation to make corresponding changes in products previously manufactured.

LEGAL REMEDIES OF PURCHASER

No action to enforce this Crown Warranty shall be commenced after expiration of the warranty period.

THIS STATEMENT OF WARRANTY SUPERSEDES ANY OTHERS CONTAINED IN THIS MANUAL FOR CROWN PRODUCTS. 9/07



CROWN

PRODUCT REGISTRATION

Crown Audio, Inc.
1718 W. Mishawaka Rd.
Elkhart, IN 46517-9439
Phone: 574-294-8000
Fax: 574-294-8329
www.crownaudio.com

Online registration is also available at <http://crownweb.crownintl.com/webregistration>.

Warranty is only valid within the country in which the product is purchased.

When this form is used to register your product, it may be mailed or faxed.

Crown Audio, Inc. Fax: 574-294-8329
1718 W Mishawaka Rd
Elkhart IN 46517

Please note that some information is required. Incomplete registrations will not be processed. * Indicates required information.

OWNER'S INFORMATION - PLEASE PRINT

* First name: _____ Middle initial: _____ * Last name: _____
Company: _____
* Mailing address: _____
* City: _____ * State: _____ * Zip Code: _____
* Country: _____ E-mail address: _____
* Phone # (include area code): _____ Fax #: _____

PRODUCT INFORMATION

* MODEL	* SERIAL #	* PURCHASE DATE
e.g. IT8000, CDi1000, PCC160	e.g. 8000000000	mo/day/yr
_____	_____	____/____/____
_____	_____	____/____/____
_____	_____	____/____/____
_____	_____	____/____/____

Product purchased from: *(Business/Individual) _____ Country: _____

Comments: _____

CUT ON THIS LINE

THIS PAGE INTENTIONALLY LEFT BLANK



Crown Audio Factory Service Information

Shipping Address: Crown Audio Factory Service, 1718 W. Mishawaka Rd., Elkhart, IN 46517

PLEASE PRINT CLEARLY

SRA #: _____ (If sending product to Crown factory service.) Model: _____ Serial Number: _____ Purchase Date: _____

PRODUCT RETURN INFORMATION

Individual or Business Name: _____

Phone #: _____ Fax #: _____ E-Mail: _____

Street Address (please, no P.O. Boxes): _____

City: _____ State/Prov: _____ Postal Code: _____ Country: _____

Nature of problem: _____

Other equipment in your system: _____

If warranty is expired, please provide method of payment. Proof of purchase may be required to validate warranty.

PAYMENT OPTIONS

I have open account payment terms. Purchase order required. PO#: _____ COD

Credit Card (Information below is required; however if you do not want to provide this information at this time, we will contact you when your unit is repaired for the information.)

Credit card information:

Type of credit card: MasterCard Visa American Express Discover

Type of credit card account: Personal/Consumer Business/Corporate

Card # _____ Exp. date: _____ * Card ID #: _____

* Card ID # is located on the back of the card following the credit card #, in the signature area. On American Express, it may be located on the front of the card. This number is required to process the charge to your account. If you do not want to provide it at this time, we will call you to obtain this number when the repair of your unit is complete.

Name on credit card: _____

Billing address of credit card: _____



H A Harman International Company