

BRICK

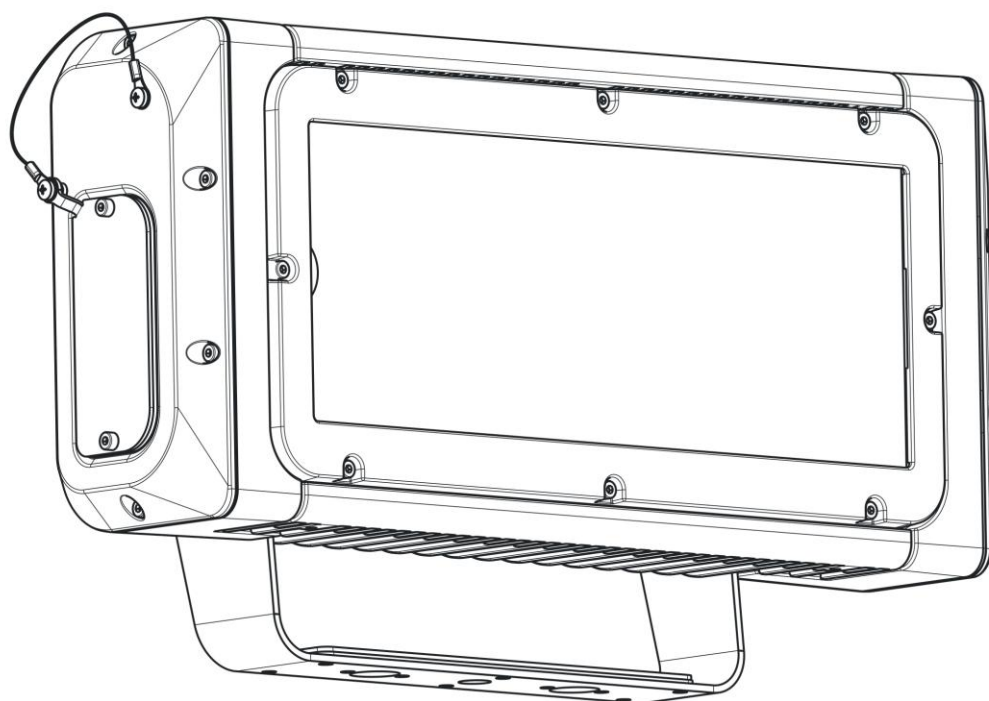

DESIGNED TO SHINE



User's Manual rel 1.1 GB

Le informazioni contenute in questo documento sono state attentamente redatte e controllate. Tuttavia non è assunta alcuna responsabilità per eventuali inesattezze. Tutti i diritti sono riservati e questo documento non può essere copiato, fotocopiato, riprodotto per intero o in parte senza previo consenso scritto della D.T.S .

D.T.S. si riserva il diritto di apportare senza preavviso cambiamenti e modifiche estetiche , funzionali o di design a ciascun proprio prodotto. D.T.S non assume alcuna responsabilità sull'uso o sull'applicazione dei prodotti o dei circuiti descritti.

The information contained in this publication has been carefully prepared and checked. However, no responsibility will be taken for any errors. All rights are reserved and this document cannot be copied, photocopied or reproduced, in part or completely, without prior written consent from D.T.S.

D.T.S. reserves the right to make any aesthetic, functional or design modifications to any of its products without prior notice. D.T.S. assumes no responsibility for the use or application of the products or circuits described herein.

Les informations contenues dans le présent manuel ont été rédigées et contrôlées avec le plus grand soin. Nous déclinons toutefois toute responsabilité en cas d'éventuelles inexactitudes. Tous droits réservés. Ce document ne peut être copié, photocopié ou reproduit, dans sa totalité ou partiellement, sans le consentement préalable de D.T.S.

D.T.S. se réserve le droit d'apporter toutes modifications et améliorations esthétiques, fonctionnelles ou de design, sans préavis, à chacun de ses produits. D.T.S. décline toute responsabilité sur l'utilisation ou sur l'application des produits ou des circuits décrits.

Las informaciones contenidas en este documento han sido cuidadosamente redactadas y controladas. Con todo, no se asume ninguna responsabilidad por eventuales inexactitudes. Todos los derechos han sido reservados y este documento no puede ser copiado, fotocopiado o reproducido, total o parcialmente, sin previa autorización escrita de D.T.S.

D.T.S. se reserva el derecho a aportar sin previo aviso cambios y modificaciones de carácter estético, funcional o de diseño a cada producto suyo. D.T.S. no se asume responsabilidad de ningún tipo sobre la utilización o sobre la aplicación de los productos o de los circuitos descritos.

INDEX:

1- SYMBOLS	4
2- GENERAL WARNING	5
3- GENERAL WARRANTY CONDITIONS	5
4- TECHNICAL FEATURES	5
5- ACCESSORIES	7
6- IMPORTANT SAFETY INFORMATION	8
6.1 Fire prevention.....	8
6.2 Prevention of electric shock.....	8
6.3 Safety	8
6.4 Level of protection against the penetration of solid and liquid objects	8
6.5 Waste Electrical and Electronic Equipment (WEEE) directive.....	9
7- INSTALLATION	9
7.1 Protection against liquids.....	11
7.2 Movement.....	11
7.3 Risk of fire	11
7.4 Forced ventilation	12
7.5 Ambient temperature	12
8- INPUT / OUTPUT CONNECTIONS	12
8.1 Internal fuse.....	13
9- DMX SIGNAL CONNECTION	14
9.1 DMX Addresses.....	15
9.2 Selecting the DMX address	15
10- RDM FUNCTIONS	15
11- FIRMWARE UPDATING	16
12- DISPLAY FUNCTIONS	17
13- REC MODE	20
14- ERROR MESSAGES	20
15- PERIODIC CLEANING	21
16- PERIODIC CONTROLS	21
17- HOLOGRAPHIC FILTER INSTALLATION	22
18- LENSES SET REPLACEMENT	23
19- BARNDOOR INSTALLATION	24
20- DMX PROTOCOL	25

1- SYMBOLS

Graphic symbols used on this manual:



THIS SYMBOL INDICATES A HOT SURFACE



THIS SYMBOL INDICATES ELECTRIC SHOCK RISK



THIS SYMBOL INDICATES GENERAL RISK

t_a 40°C

THIS SYMBOL INDICATES THE MAXIMUM OPERATING AMBIENT TEMPERATURE



THIS SYMBOL MEANS “SUITABLE FOR MOUNTING ON NORMALLY FLAMMABLE SURFACES”

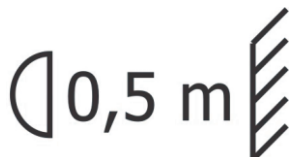

THIS SYMBOL INDICATES THE MINIMUM DISTANCE FROM THE ILLUMINATED OBJECTS



THIS SYMBOL MEANS “DO NOT STARE AT THE OPERATING LIGHT SOURCE”



Risk Group 2

THIS SYMBOL INDICATES PHOTOBIOLOGICAL SAFETY



THIS SYMBOL INDICATES THE EUROPEAN COMMUNITY DIRECTIVE 2012/19/EC ON WASTE ELECTRICAL AND ELECTRONIC EQUIPMENT (WEEE)

2- GENERAL WARNING

Read the instruction contained in this user manual carefully, as they give important information regarding safety during installation, use and maintenance.

The unit is not for household use and must be installed by a qualified electrician or experienced person.

Always disconnect the device from the mains before maintenance.

The device must always be equipped with an efficient ground connection.

3- GENERAL WARRANTY CONDITIONS

The unit is guaranteed for 36 months from the date of purchase against manufacturing material defects.

4- TECHNICAL FEATURES

OVERVIEW

The new BRICK is a high power, very compact, self-contained, IP65 LED Wash light. BRICK is suitable for various purposes, offering a range of projection angles quickly interchangeable (no tools required).

BRICK comes with an IP65 power cable plus 2 DMX cables with M / F XLR connectors (all IP65), that make it perfect for temporary lighting applications, but also for safe long-lasting installations.

Built with top quality components, BRICK gives you the best value for money by efficient design and full production automation.

DTS product codes:

03.LDB100S11FC08 BRICK FC ULTRA-NARROW lenses Black finishing

Available on demand:

03.LDB100S11FC10 BRICK FC NARROW lenses Black finishing

03.LDB100S11FC25 BRICK FC MEDIUM Flood lenses Black finishing

03.LDB100S11FC40 BRICK FC WIDE Flood lenses Black finishing

LED Technology

24 x OSTAR STAGE "N" FULL RGBW LEDs

Optical group

8° projection angle

Range of quick-mounting holographic filters included: 20° / 40° / 60°x10° (no mounting tools required)

Uniform projection on surfaces

Color generation

16 million colors

Wide palette of pure uniform Whites with variable linear color temperature (2700K – 8000K)

4- TECHNICAL FEATURES

Control

DMX 512 / RDM

10 DMX channels (Default)

4-digit 7-segment LED display + 4 soft keys

Protection

IP 65

Power supply

Built-in full-range PSU 100-240Vac 50-60 Hz

Consumption: 400VA Max

Connections

Power supply: 3 x 1 sq mm cable (1,5 m length)

DMX In/Out: 0,7 m cable with XLR 5 pins IP65 connector

Operating ambient temperature

-10° / 40°

Weight

10 Kg

Certifications



2014/35/UE ; 2014/30/UE

IEC 62471 ; IEC 695-2-1

EN 60598-1 ; EN 62471 ; EN 61347-2-13

EN 60598-2-17 ; EN 55015 EMC ; EN 61347-1

DIMENSIONS

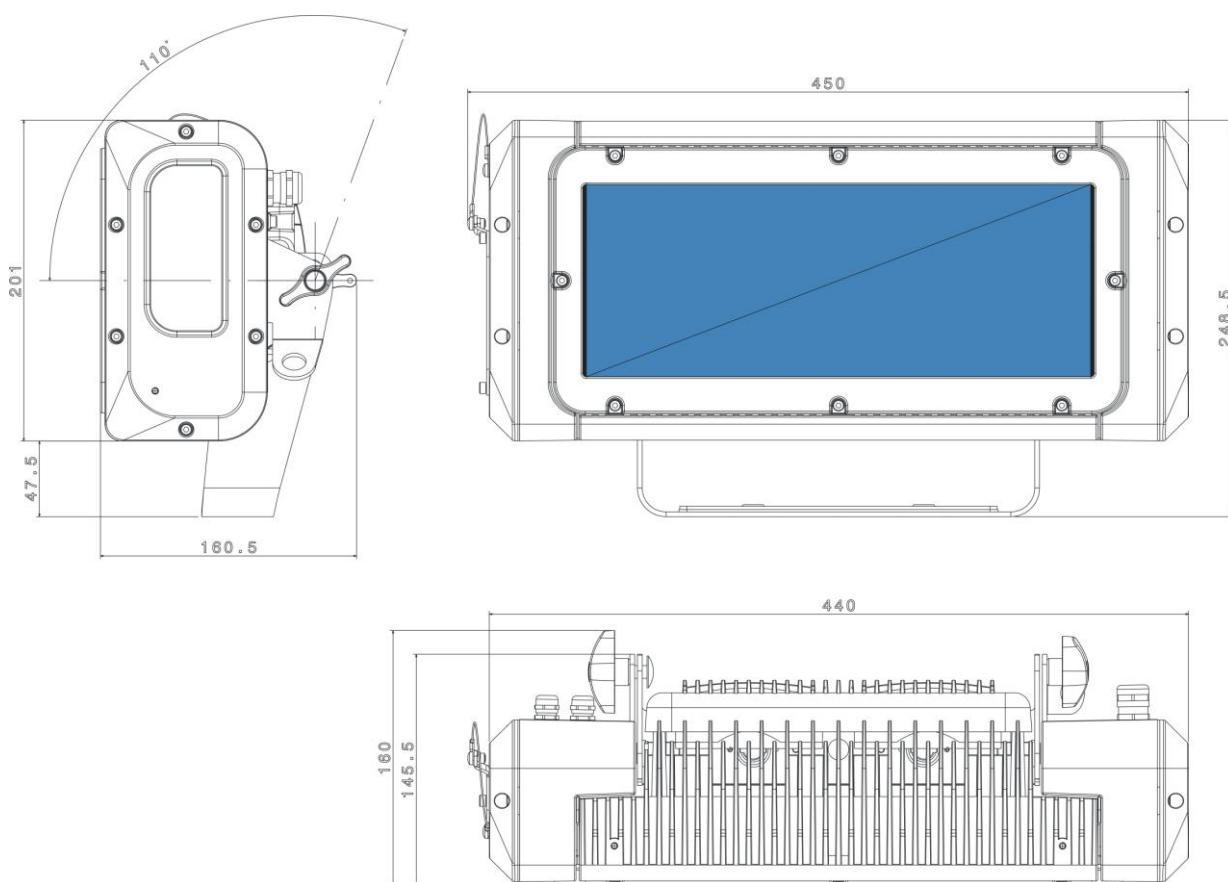

5- ACCESSORIES

As standard

- 1 x Holographic filter 20° (code 0506A043.D11)
- 1 x Holographic filter 40° (code 0506A045.D11)
- 1 x Holographic filter 60°x10° (code 0506A092.D11)
- 1 x PowerCON TRUE1 female cable connector (code 0520P066)
- 1 x PowerCON TRUE1 male cable connector (code 0520P067)
- 1 x User's Manual

Optional (on request)

- Bracket for ground installation (code 03.LA.213)
- Barndoor black finishing (code 03.LA.210)
- Permanent installation kit IP68: Power connector + 2 x DMX In/Out connectors (code 03.LA.214)
- Aliscraf clamp for tube diameter 50 mm (Max load 100 Kg) (code 0521A008)
(indicated for any kind of loads vertical / horizontal)
- Professional Quick trigger clamp (Max load 100 Kg) (code 0521A037) (not indicated for horizontal load)
- "C" Clamp G60 (Max load 50 Kg) (code 0521A004) (not indicated for horizontal load)
- Safety cable 3 mm x 60 cm (Max load 60 Kg) (code 0521A010)

6- IMPORTANT SAFETY INFORMATION

6.1 Fire prevention:

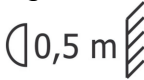

- It is permissible to place the unit on normally flammable surfaces. Suitable for mounting on normally flammable materials surfaces greater than 200°C with some combustion time lag.
- Minimum distance from the closest illuminable surface: 0,5 m. 
- Replace any blown or damaged fuses only with those of identical value (T 5A 250V). Refer to the wiring diagram if there is any doubt.
- Connect the unit to mains power via a thermal magnetic circuit breaker.

6.2 Prevention of electric shock:





- High voltage is present inside the unit. Unplug the unit prior to performing any function which involves touching the inside of the projector.
- The level of technology inherent in the BRICK requires the assistance of specialised personnel for all servicing. Please refer to an authorised DTS service centre.
- A good earth connection is essential for proper functioning of the unit.
- Never connect the unit without proper earth connection.
- The fixture should be located in places with a good air ventilation.

6.3 Safety:



- Risk Group 2 product according to EN 62471.  Risk Group 2
- CAUTION. Do not look directly into the light output. May be harmful to the eyes and skin.

- Do not stare at the operating light source. 

- The light source contained in this luminaire shall only be replaced by the manufacturer or his service agent or a similar qualified person.
- The unit is not for household use and must be installed by a qualified electrician or experienced person.
- The projector should always be installed with bolts, clamps and other tools that are capable of supporting the weight of the unit.
- Always use a second safety cable to sustain the weight of the unit in case of the failure of the main fixing point.
- The external surface of the unit, at various points, may exceed 60°C. Never handle the unit until at least 5 minutes have elapsed since the projector was turned off. 
- Never install the fixture in an enclosed area lacking sufficient air flow.

The ambient temperature should not exceed 40°C. t_a 40°C

6.4 Level of protection against the penetration of solid and liquid objects:



- The projector is classified as an outdoor appliance and its protection level against the penetration of solid and liquid objects is IP65. Suitable for wet locations.

6.5 Waste Electrical and Electronic equipment (WEEE) directive:



-The machine, accessories and packaging should be sorted for environmental-friendly Recycling.

For EC countries: according to the European Directive 2012/19/EC for Waste Electrical and Electronic Equipment and its implementation into national right, luminaires that are no longer usable must be collected separately and disposed of in an environmentally correct manner.

7- INSTALLATION

The unit is suitable for wet locations.

For outdoor installation, BRICK is provided with a Display UV Protection.

BRICK may be either floor or ceiling mounted.

For floor mounting installation, a bracket with 4 rubber mounting feet (code 03.LA.213) is available on demand.

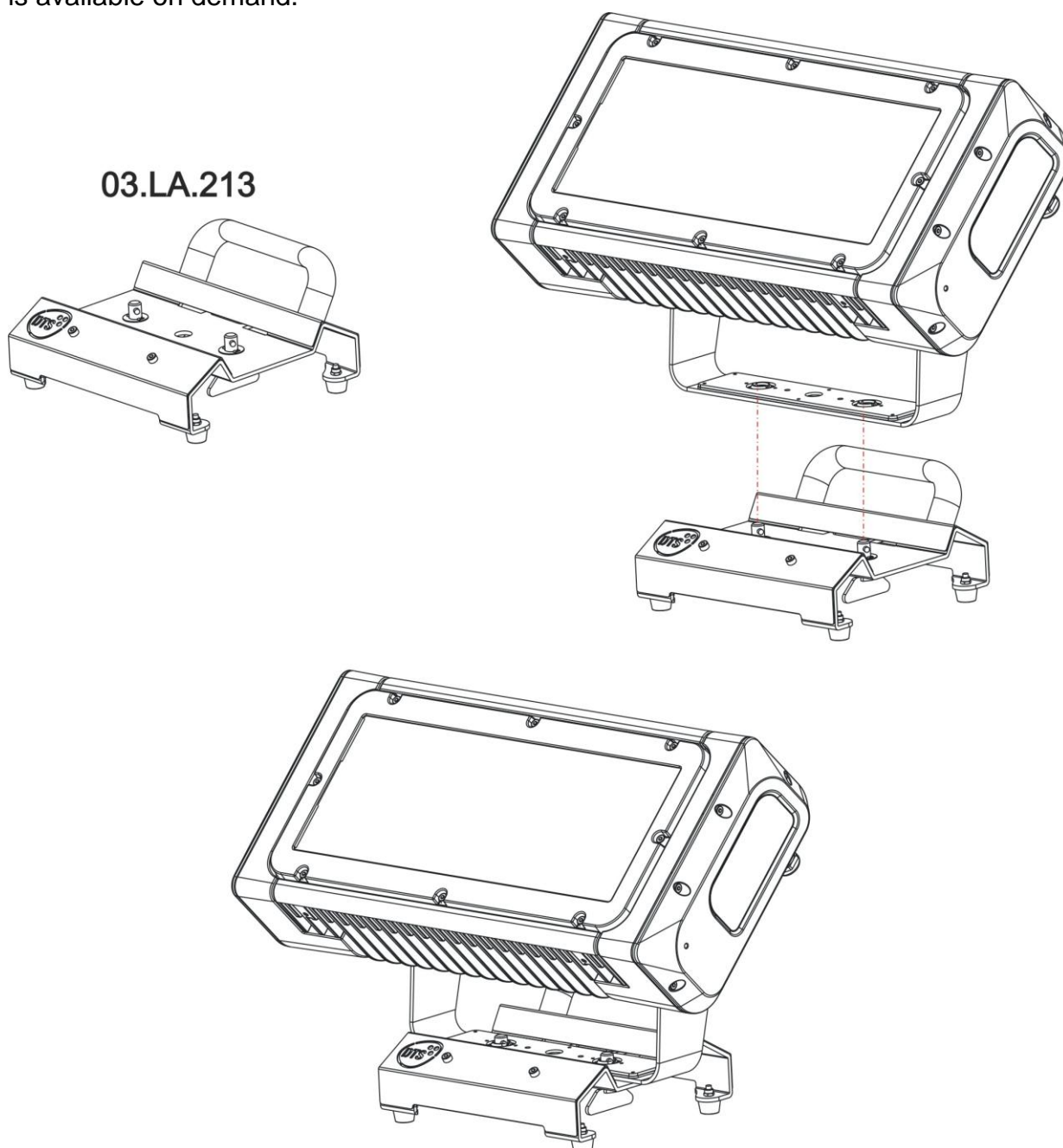

7- INSTALLATION

For ceiling mounted installation, it is recommended the use of appropriate clamps to fix the unit to the mounting surface.

The supporting structure from which the unit is hung should be capable of bearing the weight of the unit, as should any clamps used to hung it.

For outdoor application where BRICK needs to be installed vertically keep the unit display towards the floor.

A permanent installation kit IP68 (code 03.LA.214) is available on demand.

ATTENTION:

A safety cable (code 0521A010) must be securely fixed to the unit's mounting bracket and to the support structure of the projector as shown in the picture.

Fixing clamps and safety cable are available on demand.

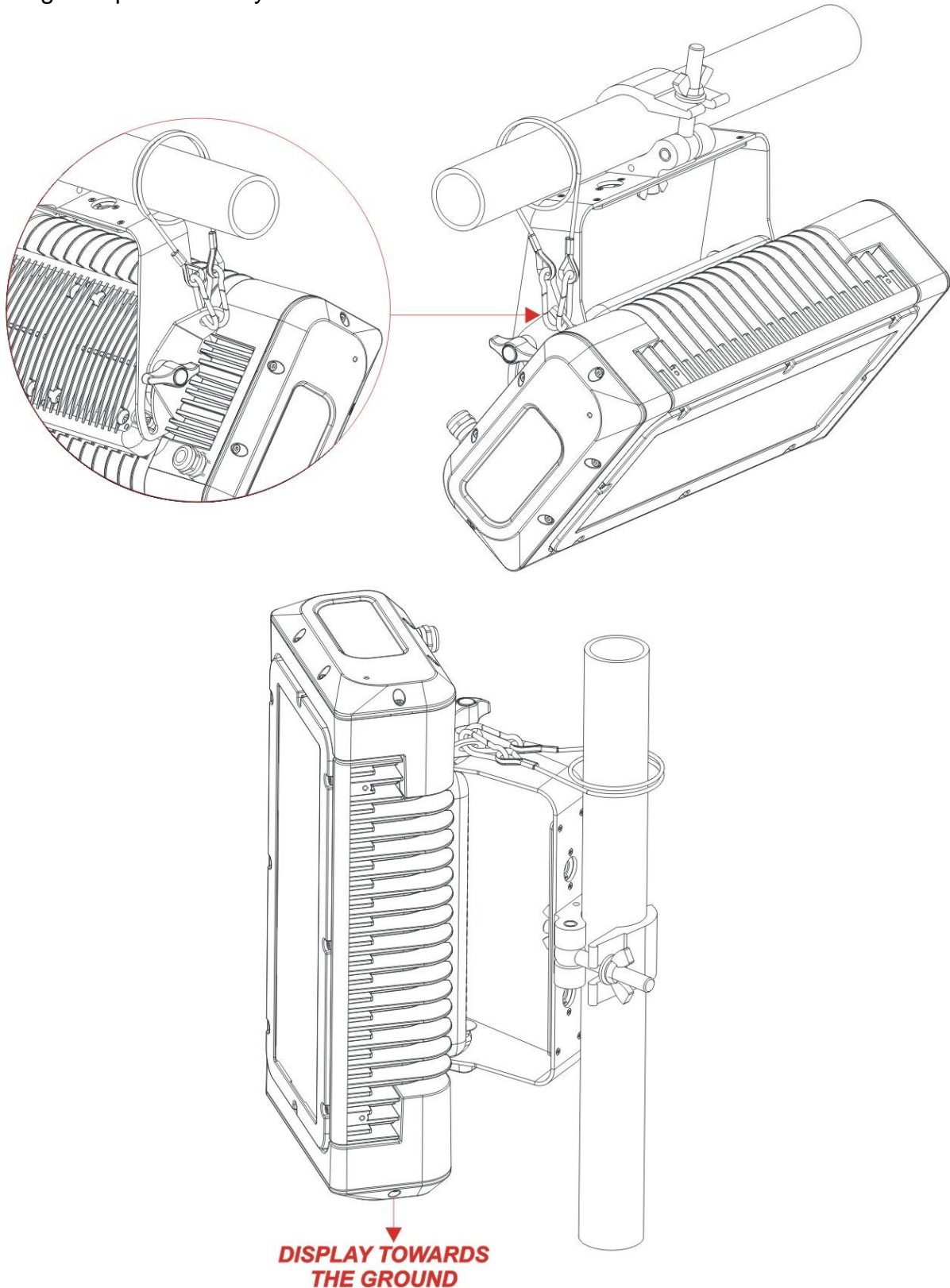

7.1 Protection against liquids

If IP65 protection is impaired for any reason, do not expose this product to external atmospheric agents, because it could be damaged.

7.2 Movement

The projector has a maximum movement of 110° for Tilt.

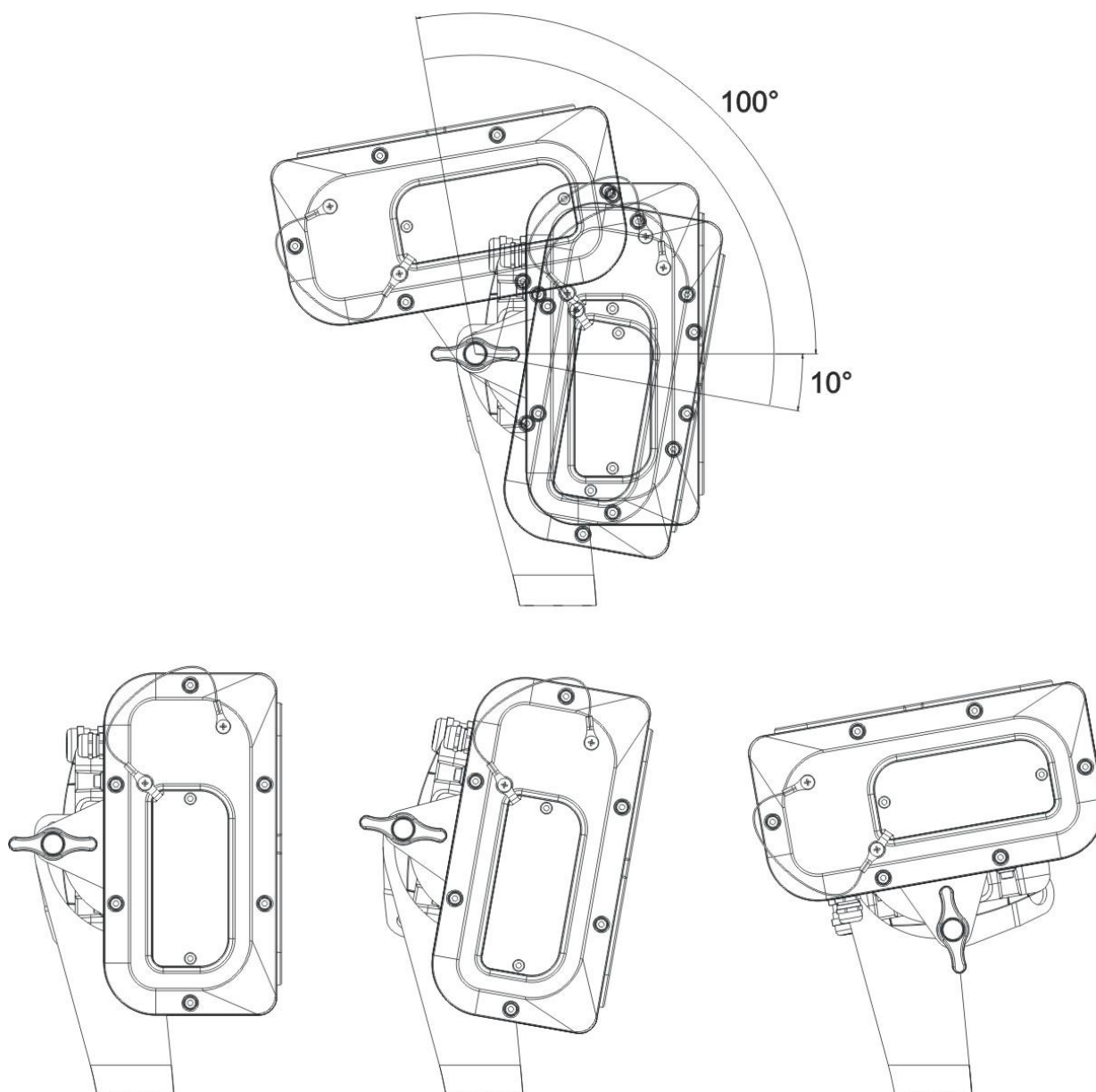

7.3- Risk of fire

Each fixture produces heat and must be installed in a well-ventilated place. It is permissible to place the unit on normally flammable materials surfaces. Suitable for mounting on normally flammable materials surfaces greater than 200°C with some combustion time lag.

Minimum distance from the object being illuminated is 0,5 m. $\varnothing 0,5 \text{ m}$ 

7.4- Forced ventilation

You will note, on inspection, that the unit features various air inlets and cooling fans. These should, under no circumstances, be blocked or obstructed whilst the projector is in operation. Doing so could cause the fixture to seriously overheat thereby compromising its proper operation.

7.5- Ambient temperature

The projector should never be installed in places that lack a constant air flow.

The ambient temperature should not exceed 40°C. t_a 40°C

8- INPUT / OUTPUT CONNECTIONS

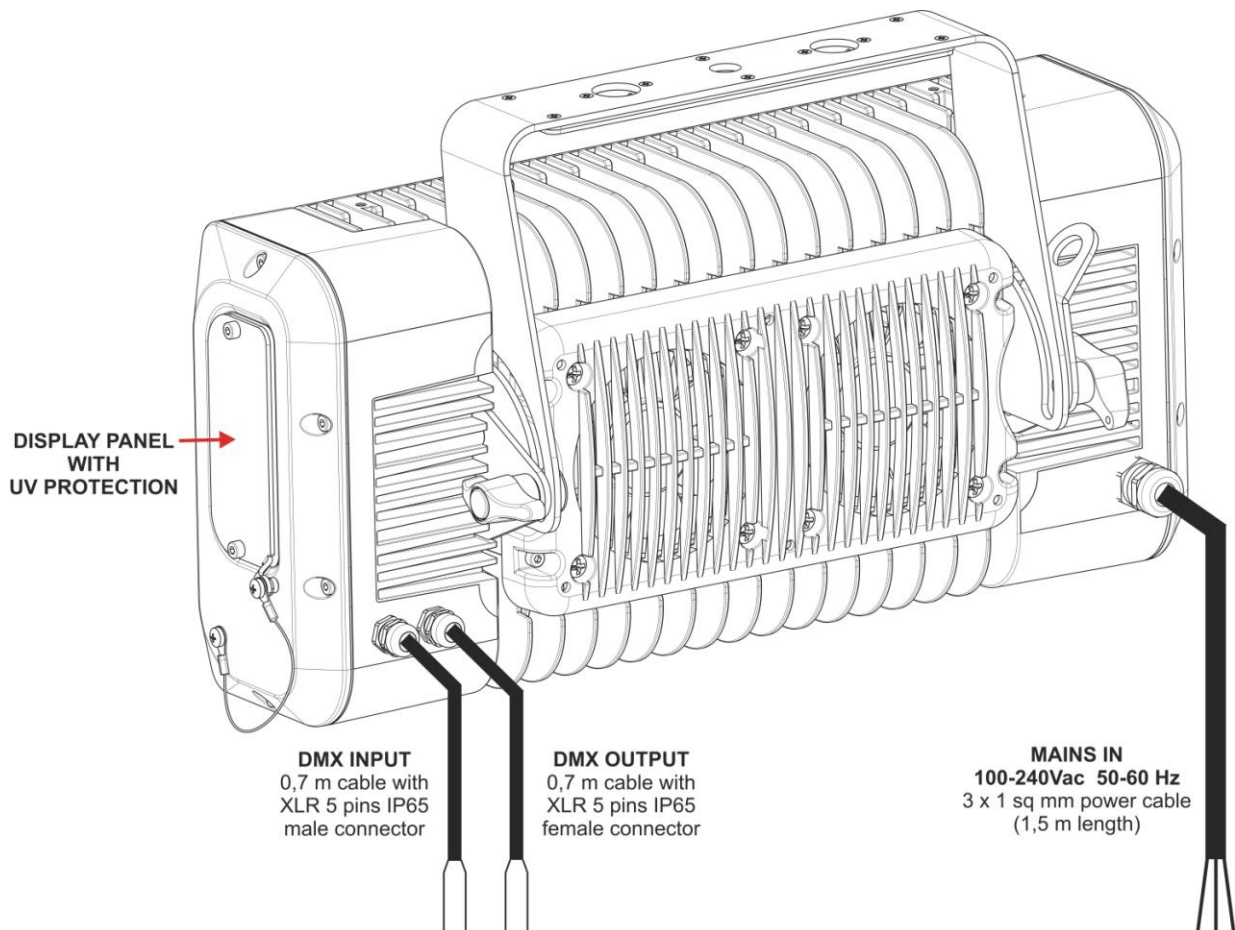

8.1- Internal Fuse

Attention: the fuse replacement must be made by DTS personnel or experienced person.

Wrong operations can damage the IP65 protection.

To access the internal fuse loose the 6 marked screws which fix the lateral cover on display panel opposite side and remove the cover.

Use only replacement fuses rated T 5A 250V.

Paying attention to the gasket put in place the lateral cover and fix it with the 6 screws previously removed.

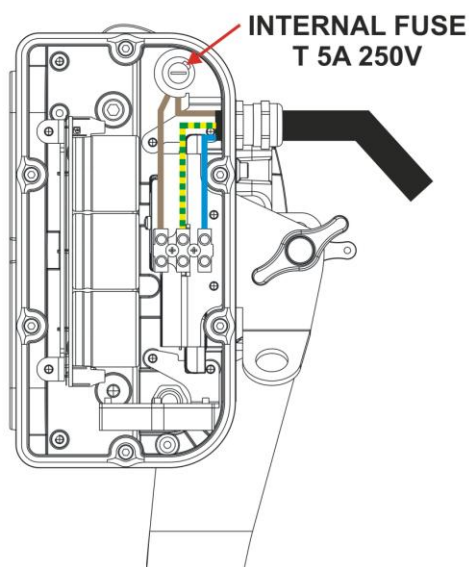
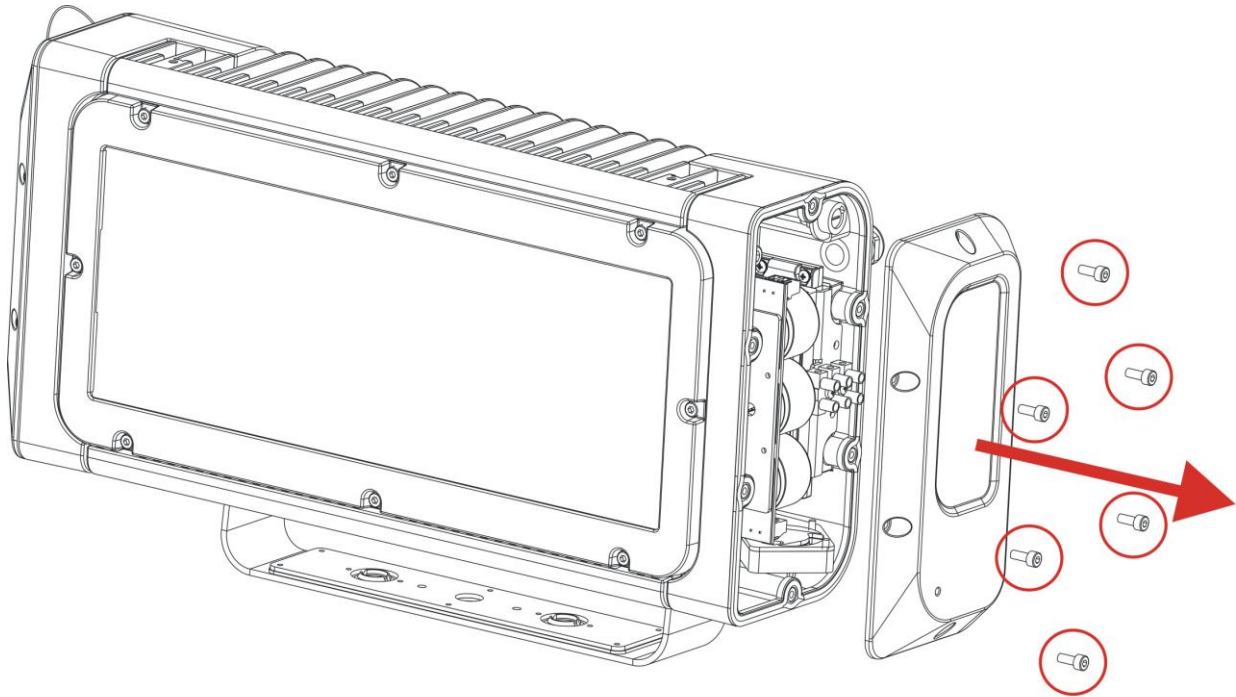

9- DMX SIGNAL CONNECTION:

The unit operates using a digital DMX 512 signal.

Connection between the controller and the unit or between units must be carried out using a two pair screened \varnothing 0.5 mm.

Ensure that the conductors do not touch each other.

Do not connect the cable ground to the DMX connector chassis.

The plug housing must be isolated. Connect the mixer signal to the DMX IN projector plug and connect it to the next projector by connecting the DMX OUT plug on the first unit to the DMX IN plug of the second one.

In this way, all the projectors are cascade connected.

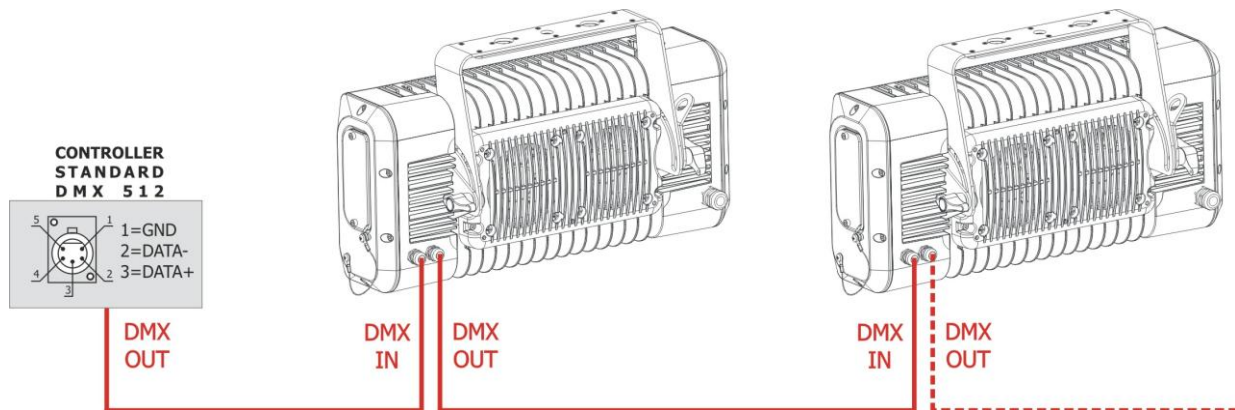

If the display showing the DMX address flashes, then one of the following errors has occurred:

- DMX signal not present
- DMX reception problem

For Installations where long distance DMX cable connections are needed, we suggest to use a DMX terminator.

The DMX terminator is a male XLR 3-5 pins connector with a 120 ohm resistor Between pin 2 and 3.

The DMX terminator must be plugged into the last unit (DMX out panel connector) of the DMX line.

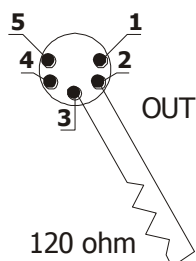

PLACE A 120 OHM RESISTOR BETWEEN PIN 2 AND 3 OF A MALE XLR CONNECTOR AND PLUG IT INTO THE DMX OUT PANEL CONNECTOR OF THE LAST UNIT CONNECTED TO THE DMX LINE

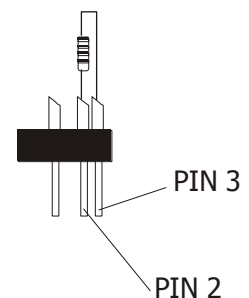

9.1 DMX addresses

BRICK can be controlled with 10 DMX channels (Default).
In order to use the unit in 10 DMX channels mode (Default), set the following addresses on the mixer:

Projector 1	A001	
Projector 2	A011	If you want to select the next projector, just add "10"
Projector 3	A021	
.....	A.....	
projector 6	A051	

9.2 Selecting the DMX address

- 1) Press the UP-DOWN key until you reach the required DMX address. The numbers on the display will start to flash (but the new DMX address hasn't yet been set).
- 2) Press ENTER to confirm your selection. The numbers on the display will stop flashing and the projector is now controlled by the new DMX address.

TIPS: if you keep pushed the UP or DOWN keys, the channels are calculated more quickly and you get a faster selection.

- 2) Press ENTER to confirm your selection. The numbers on the display will stop flashing and the projector is now controlled by the new DMX address.

10- RDM FUNCTIONS

By using a RDM controller it is possible to set DMX address, DMX mode and other parameters.

BRICK accepts the following RDM commands:

DEVICE_INFO	To read the following parameters: <ul style="list-style-type: none"> • RDM protocol version • Fixture model ID • Fixture type • Software version ID • DMX channels • DMX mode • DMX address • Total sub-fixtures • Total sensors
IDENTIFY_DEVICE	All LED channels ON at max power to identify the fixture
DMX_START_ADDRESS	To read / set the DMX address
SOFTWARE_VERSION_LABEL	Software version ID
SUPPORTED_PARAMETERS	List of all supported parameters
PARAMETER_DESCRIPTION	Description / details of Manufacturer Specific parameter as "NO DMX ACTION"
DMX_PERSONALITY	To set the DMX mode
DMX_PERSONALITY_DESCRIPTION	Description / details of the DMX mode
DEVICE_MODEL_DESCRIPTION	Description / details of the Fixture model
MANUFACTURER_LABEL	Producer ID
SENSOR_DEFINITION, SENSOR VALUE	LED Temperature

10- RDM FUNCTIONS

RDM MANUFACTURER-SPECIFIC PIDs	
NO DMX ACTION	<p>To set the desired fixture's behavior in case DMX signal is missing or not available.</p> <p>1 = Black-out</p> <p>2 = CHPR (demo program steps 01..16 same as menu "NDMX > CHPR")</p> <p>3 = All channels @ 100%</p> <p>4 = CUSTOM (RGBW values set into the menus "RED NO DMX" "GREEN NO DMX" "BLUE NO DMX" "WHITE NO DMX")</p> <p>5 = Keep last valid DMX signal</p>

11- FIRMWARE UPDATING

To update the software version of the BRICK you need:

- DTS RED BOX interface (DTS Code 03.LA.008).
- USB-DMX Driver for the DTS RED BOX interface.
- "DTS Firmware Upgrade Utility v.2.02" program installed on PC.
- Latest firmware release available for BRICK unit.

Updating the software version.

Please follow the procedure below to perform the update:

1. Install the DTS RED BOX USB-DMX driver on the PC you will use to update the unit software.
2. Connect the DTS RED BOX interface to a spare USB port on the PC (be sure that internal switch on DTS RED BOX is set to COM).
3. Connect the unit DMX input to the DTS RED BOX DMX output with a standard DMX cable and turn ON the unit.
4. Send the new software version into the unit by using "DTS Firmware upgrade Utility v.2.02" program. At the end of the procedure, the unit will reset.

12- DISPLAY FUNCTIONS

The BRICK display panel shows all the available control menus. Using these options, it is possible to change the fixture's setting. Changing the DTS settings can vary the functions of the unit so that it does not respond to the DMX 512 used to control it. Carefully follow the instructions below before carrying out any variations or selections.



MENU	<ul style="list-style-type: none"> • To access the control menus in the display panel. • To return to the previous level in the menu structure without making a change. • To exit the menus.
ENTER	<ul style="list-style-type: none"> • To select any required menu. • To confirm any changes.
UP / DOWN	<ul style="list-style-type: none"> • To navigate the menus structure. • To change any value.

Firmware release	1.00
-------------------------	-------------

MAIN MENU	LEVEL 1	LEVEL 2	LEVEL 3	FUNCTION
dISP	Pos1	AA		Display normal orientation for floor mounting position (Default)
		BB		Display inverted orientation for suspended mounting position
	Stby	OFF		Display always ON (Default)
		on		Display goes OFF after 10 seconds
Mode	10 ch			Allows to select 10 DMX channels mode (Default)
	RGBW			Allows to select RGBW mode (4 DMX channels)
LEd	SntH	OFF-20		Allows to select the value of the delay (in milliseconds) for Dimmer channel reaction to DMX or Program variation. Off = Instant response to DMX variation. 4 = 100 ms Smooth response to DMX variation (Default) 20 = 500 ms Smooth response to DMX variation.
			cONP	QuAd
	LinE	Allows to select Linear current output		
	Sync	610-5000		Allows to adjust the PWM frequency value (Hz) in order to reduce flickering in the process of your camera recordings. Default = 610 Hz
	bst	on		Allows to increase the LED's current from 1050mA to 1500mA per channel Default = ON
		OFF		
	Auto	cHPr	SPEE	1-3600
WAIt			1-3600	
cPO1		red	0-255	16 customizable Colour Macros. RGBW values selectable by user (Default = 255) .
		GrEE	0-255	
		bluE	0-255	
		WHIt	0-255	
cP16				
cRIn		SPEE	1-3600	Rainbow colours effect. Speed time value (in seconds) selectable by user (Default = 10) .
cU01				16 Colour Macros as on DMX channel 9 (MACRO COLOR). Default = 01
cU16				
2700				12 White color temperature from 2700K to 8000K as on DMX channel 8 (CCT). Default = 2700K
8000				
dInn				Dimmer level selectable by user as on DMX channel 6 (DIMMER) Default = 255
SHUt				Shutter level selectable by user as on DMX channel 5 (SHUTTER) Default = 15
Esc			Esc from automatic mode.	

MAIN MENU	LEVEL 1	LEVEL 2	LEVEL 3	FUNCTION
rEc	10cH	r001		In DMX Recorder mode it is possible to create and store the scenes of the CHPR menu by using an external DMX controller. The unit must be set to 10 DMX channels mode. Refer to "REC MODE" at page 20.
		n001		
		n016		
SLAV	SurE	SLU		Slave mode. The unit is forced to DMX address 1 and 10 DMX channels mode receiving signal from the unit set in Auto mode.
		ESc		Esc from slave mode
FAn	Std			Allows to select the internal fans speed. Standard mode: High fans speed. Silent mode: Low fans speed for a very low noise operation. Default = STD
	SIL			
ndnH	LdnH			No DMX action. Keep last valid DMX signal (Default)
	oFF			Black-out
	cHPR	SPEE	1-3600	Chase with 16 steps previously created in REC mode as per AUTO > CHPR menu. Speed time and wait time values (in seconds) selectable by user (Default = 10) . In Auto mode the unit do generate DMX for slave units.
		WAIt	1-3600	
	100			All channels @ 100%
	cUsT	rEd	0-255	Custom. RGBW values selectable by user (Default = 255) .
		GrEE	0-255	
bluE		0-255		
WHIt		0-255		
dFSE	SurE			To restore default settings
tEMP	LEd	025.0		LED temperature monitoring
	Micr	025.0		Micro controller temperature monitoring
	drU1	025.0		Outputs 1 and 2 of LED Driver board temperature monitoring
	drU2	025.0		Output 3 and 4 of LED Driver board temperature monitoring
tIME	rEd			Shows the total unit life time and the RGBW LEDs life time
	GrEE			
	bluE			
	WHIt			
	unit			
SoFt	v.1.00			Software version

13- REC MODE

DMX Recorder mode

For the programming of ChPr by using a DMX controller, besides the 10 channels necessary to control the unit a further 3 DMX channels are needed.

So that in RECORDER mode (via DMX) the unit will need 13 channels to be correctly programmed.

The three new DMX channels are:

DMX channel 11 = SCENES channel

From 0-10 = no function (r001)

From 11-255 are displayed the programmable scenes (max 16 scenes from M001 to M0016)

DMX channel 12 = EDIT channel:

-From 0-19 = no function

-From 20-234 the unit runs the configuration given by the received input DMX values.

With the channel SCENES it is possible to pass from one step to the next while with REC it is possible to record the selected scene.

-From 235-255 the unit runs the configuration given by the received input DMX values closing the sequence as last scene.

With the channel REC it is possible to record the selected scene as last scene.

DMX channel 13 = RECORDING channel

Records the set scene with a variation between 0 to 255 (the display flashes indicating that the scene has been recorded). It is advised that you keep the REC channel set to 0 and to run through the 255 only once you have decided to save the scene. If ChPr is not closed, by indicating the last scene (Edit channel between 235-255), in playback mode all 16 scenes will be played through even if not programmed.

14- ERROR MESSAGES

ERROR SHOWED ON DISPLAY	APPEARS WHEN
<i>LEd SEnSor Error</i>	LED thermal sensor damaged (open or in short circuit). Unit immediately goes in black-out.
<i>LEd ouErTEmPERAturE</i>	LED temperature detected over 100°C. Unit immediately goes in black-out.
<i>Micro SEnSor Error</i>	Micro controller thermal sensor damaged (open or in short circuit). Unit immediately goes in black-out.
<i>Micro ouErTEmPERAturE</i>	Micro controller temperature detected over 100°C. Unit immediately goes in black-out.
<i>drU1 SEnSor Error</i>	Thermal sensor on outputs 1 and 2 of LED Driver board damaged (open or in short circuit). Unit immediately goes in black-out.
<i>drU1 ouErTEmPERAturE</i>	Temperature detected over 100°C on outputs 1 and 2 of LED Driver board. Unit immediately goes in black-out.
<i>drU2 SEnSor Error</i>	Thermal sensor on outputs 3 and 4 of LED Driver board damaged (open or in short circuit). Unit immediately goes in black-out.
<i>drU2 ouErTEmPERAturE</i>	Temperature detected over 100°C on outputs 3 and 4 of LED Driver board. Unit immediately goes in black-out.

15- PERIODIC CLEANING

Lenses Front Glass:

The dust can reduce the luminous output substantially. Regularly clean the lenses front glass using a soft cotton cloth, dampened with a specialist glasses cleaning solution.

16- PERIODIC CONTROLS

Mechanical parts:

Periodically check all mechanical parts and the gaskets. Please refer to an authorised DTS service centre for any operation involving of the unit if needed.

Electrical components:

Check for unit proper earthing. Please refer to an authorised DTS service centre for any operation involving of the unit if needed.

Fuse replacement:

Locate the internal fuse, which protects the electronics, in the BRICK.

Using a multimeter, test the condition of the fuse, replacing it with one of equivalent type (T 5A 250V).

Attention: Disconnect mains power prior to remove the fuse to be tested.

17- HOLOGRAPHIC FILTER INSTALLATION

BRICK offers a range of holographic filters quickly interchangeable (no tools required).

To properly install the holographic filter:

- 1 - Put in place the bottom edge of the filter.
- 2 - Bend the filter.
- 3 - Insert the top edge of the filter.

For permanent outdoor installation, the holographic filter can also be mounted internally.

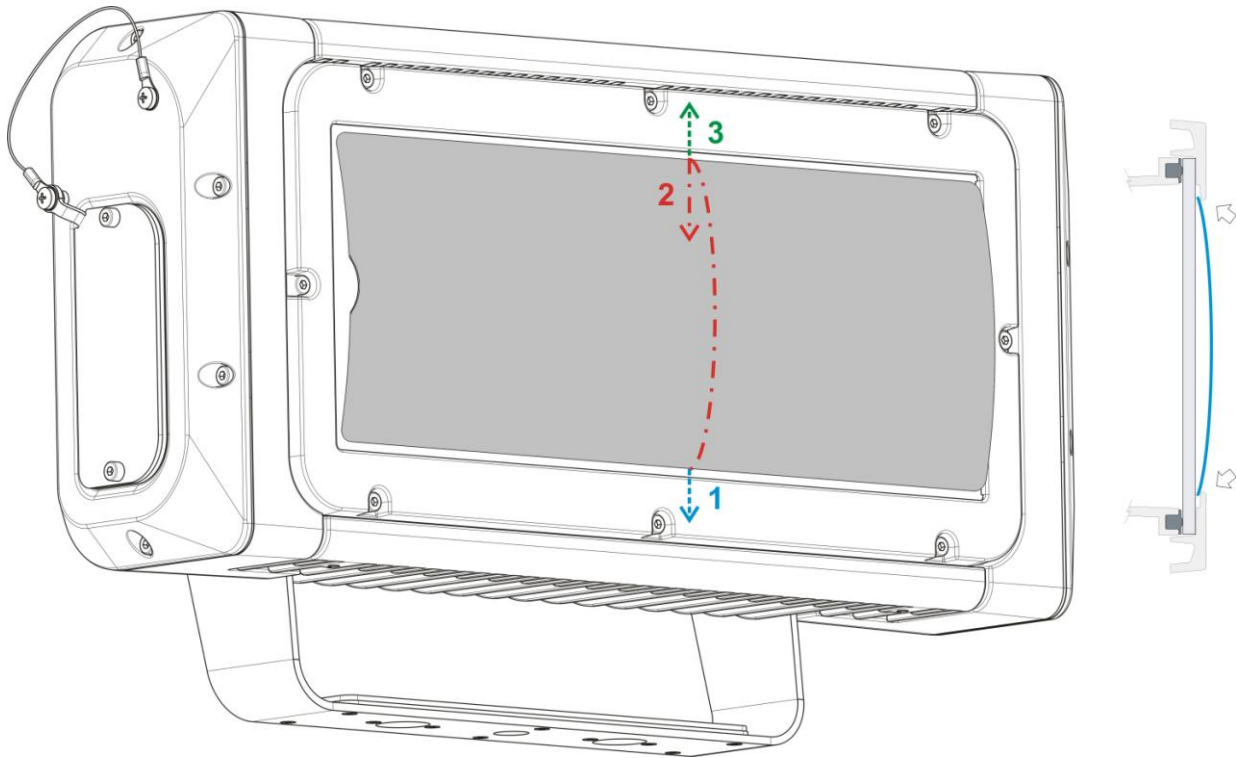

To remove the filter simply lift with a finger the filter on the side with the opening as shown in the picture.

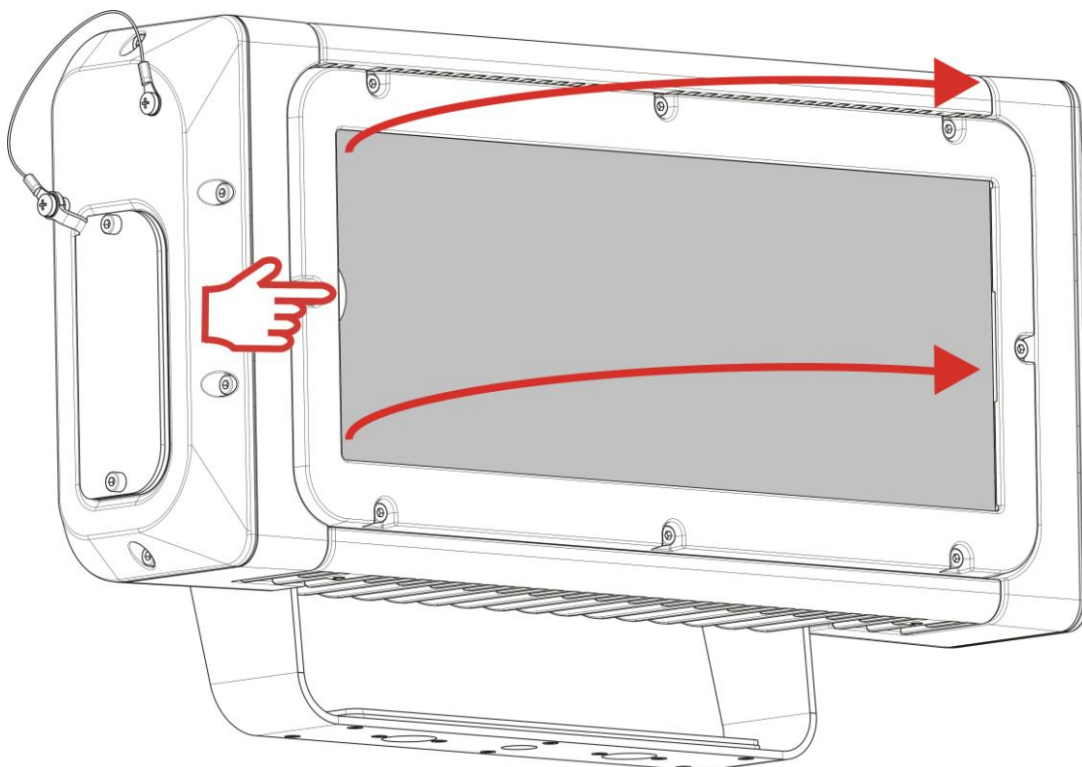

18- LENSES SET REPLACEMENT

Attention: the lenses set replacement must be made by DTS personnel or experienced person.

Wrong operations can damage the IP65 protection.

1 – Remove the front screen with the protection glass by loosening the 8 marked screws.

2 – Remove the original lenses set by loosening the 4 marked screws.

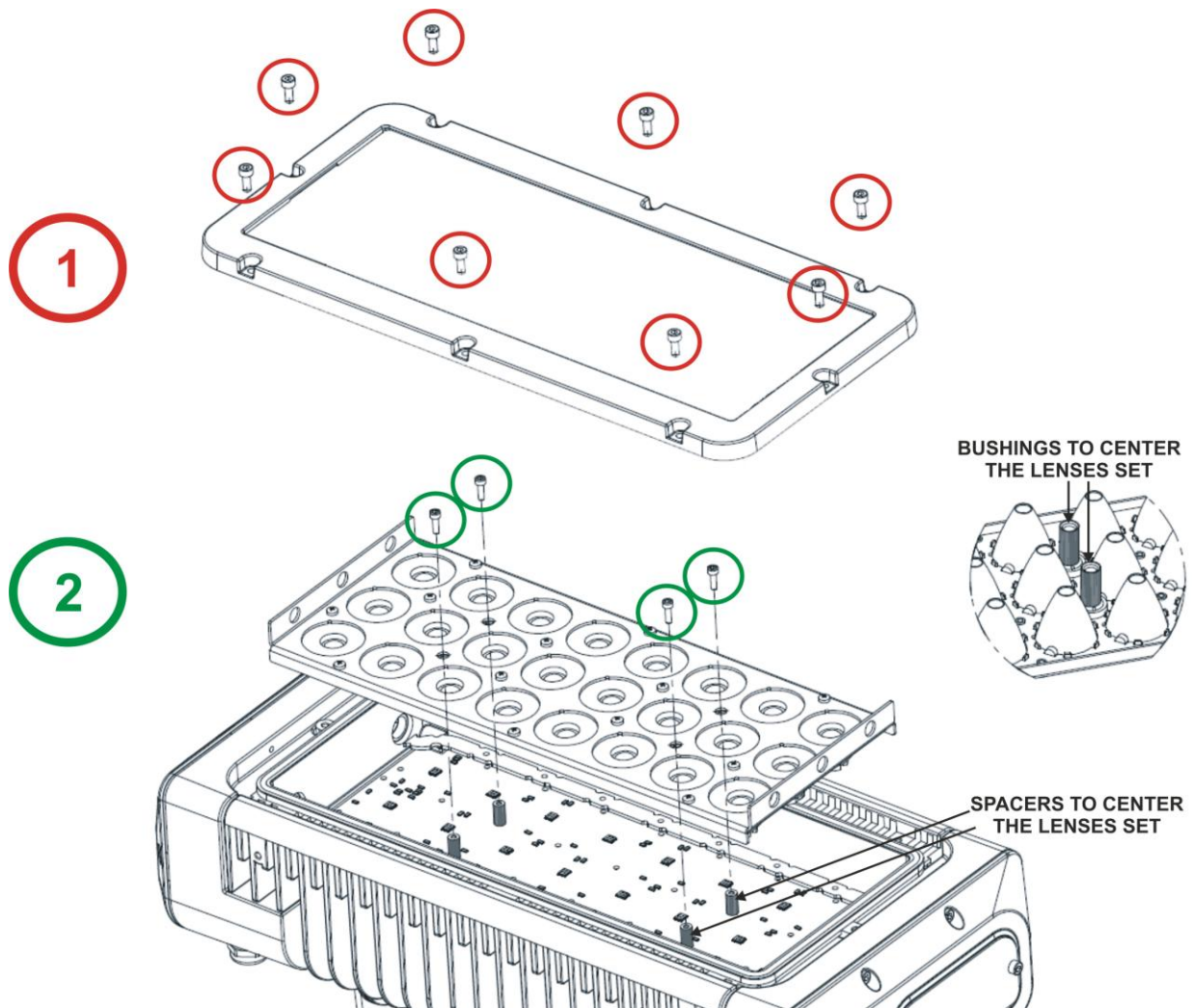

19- BARNDOOR INSTALLATION

The Barndoor for BRICK (code 03.LA.210) is available on demand.
Fix the barndoor on the BRICK by using the 4 marked knobs provided in the box.
Once installed, fix the safety cable on the lateral cover by using the screw provided in the box as shown in the picture.

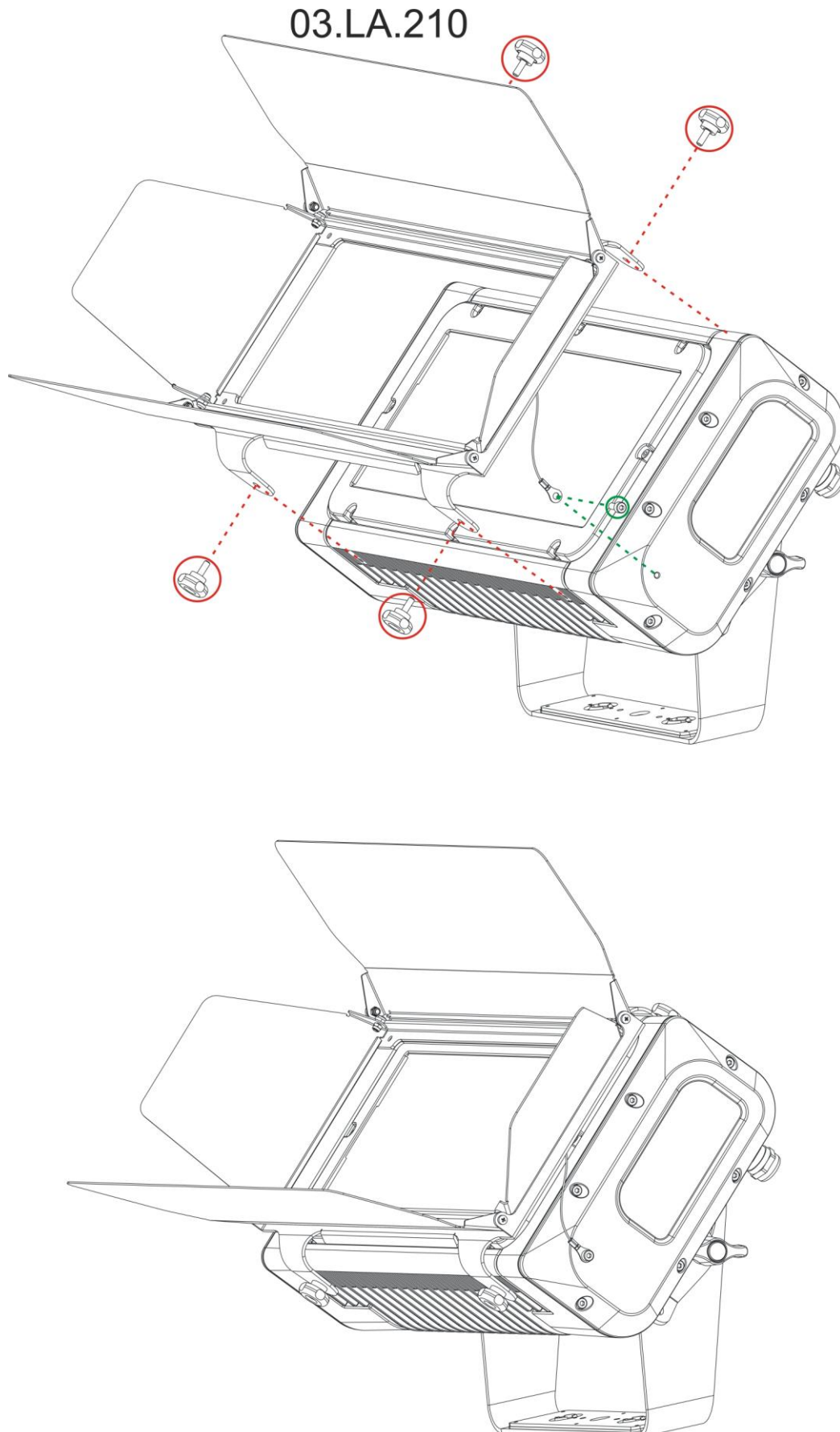

20- DMX PROTOCOL**10 CHANNELS MODE (Default)**

- 1 RED**
- 2 GREEN**
- 3 BLUE**
- 4 WHITE**
- 5 SHUTTER**
- 6 DIMMER**
- 7 DIMMER FINE**
- 8 CCT**
- 9 MACRO COLOR**
- 10 FUNCTIONS**

<i>Ch</i>	<i>Name</i>	<i>DMX levels</i>	
1	RED	0..255	Proportional color from min to max
2	GREEN	0..255	Proportional color from min to max
3	BLUE	0..255	Proportional color from min to max
4	WHITE	0..255	Proportional color from min to max
5	SHUTTER	0..9	Black-out
		10..19	Open
		20..29	Black-out
		30..119	Strobe (da 3,27 s a 30 ms)
		120..149	Pulse up (da 42,6 s a 120 ms)
		150..179	Pulse down (da 42,6 s a 120 ms)
		180..204	Random strobe (Warm White, Cold White, Dimmer, Dimmer Fine active)
		205..229	Independent random strobe (Dimmer, Dimmer Fine active)
		230..255	Open
6	DIMMER	0..255	Proportional dimmer from min to max
7	DIMMER FINE	0..255	Proportional dimmer from min to max
8	CCT	0..010 — No func. 011 — 2700K 033 — 3000K 055 — 3200K 077 — 3500K 099 — 4000K 121 — 4500K 143 — 5000K 165 — 5600K 187 — 6000K 209 — 6500K 232 — 7000K 255 — 8000K	Linear color temperature correction from 2700K to 8000K. Relevant CCT (Correlated Color Temperature) values: 11 = 2700K 33 = 3000K 55 = 3200K 77 = 3500K 99 = 4000K 121 = 4500K 143 = 5000K 165 = 5600K 187 = 6000K 209 = 6500K 232 = 7000K 255 = 8000K

<i>Ch</i>	<i>Name</i>	<i>DMX levels</i>	
9	MACRO COLOR	0..14	No function
		15..24	COL 1: LEE FILTER NO. 19 "FIRE" (R255 G16 B0 W0)
		25..34	COL 2: LEE FILTER NO. 20 "MEDIUM AMBER" (R255 G84 B0 W0)
		35..44	COL 3: LEE FILTER NO. 25 "SUNSET RED" (R255 G48 B2 W0)
		45..54	COL 4: LEE FILTER NO. 101 "YELLOW" (R255 G135 B0 W0)
		55..64	COL 5: LEE FILTER NO. 104 "DEEP AMBER" (R255 G130 B0 W0)
		65..74	COL 6: LEE FILTER NO. 106 "PRIMARY RED" (R255 G0 B0 W0)
		75..84	COL 7: LEE FILTER NO. 111 "DARK PINK" (R255 G0 B0 W97)
		85..94	COL 8: LEE FILTER NO. 113 "MAGENTA" (R255 G3 B3 W8)
		95..104	COL 9: LEE FILTER NO. 118 "LIGHT BLUE" (R0 G250 B52 W40)
		105..114	COL 10: LEE FILTER NO. 122 "FERN GREEN" (R115 G255 B0 W19)
		115..124	COL 11: LEE FILTER NO. 126 "MAUVE" (R255 G0 B55 W0)
		125..134	COL 12: LEE FILTER NO. 137 "LAVENDER" (R232 G197 B49 W37)
		135..144	COL 13: LEE FILTER NO. 139 "PRIMARY GREEN" (R30 G255 B0 W0)
		145..154	COL 14: LEE FILTER NO. 147 "APRICOT" (R163 G63 B2 W7)
		155..164	COL 15: LEE FILTER NO. 154 "PALE ROSE" (R255 G110 B0 W76)
		165..174	COL 16: LEE FILTER NO. 181 "CONGO BLUE" (R35 G45 B255 W0)
		175..184	RGB RAINBOW COLOR MIXING: SPEED 1 (6 SEC.)
		185..194	RGB RAINBOW COLOR MIXING: SPEED 2 (15 SEC.)
		195..204	RGB RAINBOW COLOR MIXING: SPEED 3 (30 SEC.)
		205..214	RGB RAINBOW COLOR MIXING: SPEED 4 (45 SEC.)
		215..224	RGB RAINBOW COLOR MIXING: SPEED 5 (60 SEC.)
		225..234	RGB RAINBOW COLOR MIXING: SPEED 6 (120 SEC.)
		235..244	RGB RAINBOW COLOR MIXING: SPEED 7 (150 SEC.)
		245..255	RGB RAINBOW COLOR MIXING: SPEED 8 (180 SEC.)

<i>Ch</i>	<i>Name</i>	<i>DMX levels</i>	
10 10	FUNCTIONS (staying on desired option for 5 seconds) FUNCTIONS (staying on desired option for 5 seconds)	0..14	No function
		15..24	SMOOTH OFF
		25..26	SMOOTH 1 (25 ms)
		27..28	SMOOTH 2 (50 ms)
		29..30	SMOOTH 3 (75 ms)
		31..32	SMOOTH 4 (100 ms) (DEFAULT)
		33..34	SMOOTH 5 (125 ms)
		35..36	SMOOTH 6 (150 ms)
		37..38	SMOOTH 7 (175 ms)
		39..40	SMOOTH 8 (200 ms)
		41..42	SMOOTH 9 (225 ms)
		43..44	SMOOTH 10 (250 ms)
		45..46	SMOOTH 11 (275 ms)
		47..48	SMOOTH 12 (300 ms)
		49..50	SMOOTH 13 (325 ms)
		51..52	SMOOTH 14 (350 ms)
		53..54	SMOOTH 15 (375 ms)
		55..56	SMOOTH 16 (400 ms)
		57..58	SMOOTH 17 (425 ms)
		59..60	SMOOTH 18 (450 ms)
		61..62	SMOOTH 19 (475 ms)
		63..64	SMOOTH 20 (500 ms)
		65..74	GAMMA CORRECTION (σ/P) QUADRATIC (DEFAULT)
		75..84	GAMMA CORRECTION (σ/P) LINEAR
		85..104	OUTPUT FREQUENCY 610 Hz (DEFAULT)
		105	OUTPUT FREQUENCY 800 Hz
		106	OUTPUT FREQUENCY 1000 Hz
		107	OUTPUT FREQUENCY 1500 Hz
		108	OUTPUT FREQUENCY 2000 Hz
		109	OUTPUT FREQUENCY 2500 Hz
		110	OUTPUT FREQUENCY 3000 Hz
		111	OUTPUT FREQUENCY 3500 Hz
		112	OUTPUT FREQUENCY 4000 Hz
		113	OUTPUT FREQUENCY 4500 Hz
		114	OUTPUT FREQUENCY 5000 Hz
		115..134	RESERVED
		135..144	BOOST ON (DEFAULT)
		145..154	BOOST OFF
		155..164	DISPLAY STAND-BY OFF (DEFAULT)
		165..174	DISPLAY STAND-BY ON
		175..176	NO DMX ACTION – KEEP LAST DMX (DEFAULT)
		177..178	NO DMX ACTION – Black-out
		179..180	NO DMX ACTION – RGB @ 100% (WHITE channel OFF)
		181..182	NO DMX ACTION – CHPR STEPS 01..16 WAIT and SPEED time selectable via "NDMX>CHPR" menu
		183..184	NO DMX ACTION – CUSTOM RGBW values selectable via "NDMX>CUSTOM" menu or via RDM Custom PID
		185..234	RESERVED
		235..244	FAN STANDARD MODE (DEFAULT)
		245..252	FAN SILENT MODE
		253..255	SET FUNCTIONS TO DEFAULT: SMOOTH = 4; GAMMA CORRECTION = QUADRATIC; OUTPUT FREQUENCY = 610 Hz; BOOST = ON; DISPLAY STAND BY = DISABLE; NO DMX ACTION = KEEP LAST DMX; FAN = STANDARD MODE

“RGBW” MODE (4 CHANNELS)

- 1 RED**
- 2 GREEN**
- 3 BLUE**
- 4 WHITE**

<i>Ch</i>	<i>Name</i>	<i>DMX levels</i>	
1	RED	0..255	Proportional color from min to max
2	GREEN	0..255	Proportional color from min to max
3	BLUE	0..255	Proportional color from min to max
4	WHITE	0..255	Proportional color from min to max

NOTES

NOTES

NOTES

The information contained in this publication has been carefully prepared and checked. However, no responsibility will be taken for any errors. All rights are reserved and this document cannot be copied, photocopied or reproduced, in part or completely, without prior written consent from DTS.

DTS reserves the right to make any aesthetic, functional or design modifications to any of its products without prior notice. DTS assumes no responsibility for the use or application of the products or circuits described herein.

MADE IN ITALY



DESIGNED TO SHINE

ISO 9001:2008

DTS quality system
is certified to the
ISO 9001:2008 standard

PROUDLY
MADE IN ITALY



DTS products are designed
and manufactured at the
DTS plants in Italy



05171291

D.T.S. Illuminazione s.r.l. – Via Fagnano Selve 10-12-14 47843

Misano Adriatico (RN) Italia

Tel.: +39 0541 611131. Fax + 39 0541 611111

info@dts-lighting.it www.dts-lighting.it